

kreoo

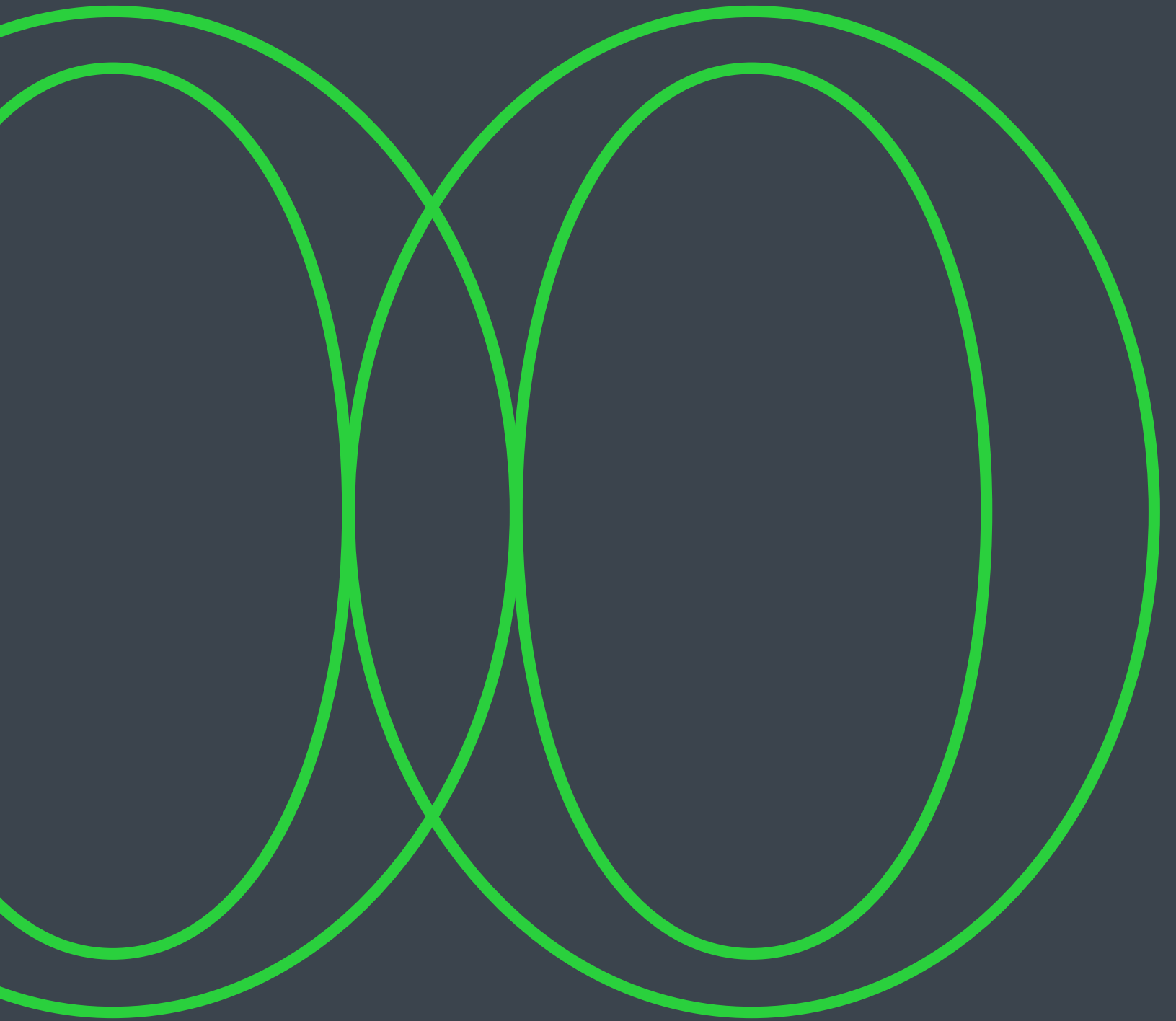

Living
Collection

Tavoli e sedute / Tables and seating systems

Tavolo / Table

Arcaico	8
Ellenico	20
Pluvio	26
Torre Maxi	30

Tavolo e tavolino /

Table and coffee table

Kalende Collection	36
More	42

Tavolino / Coffee table

Jackie	50
John	54
Nodo	58
Tangram Mini	64

Tavolino e sistema di sedute /

Coffee table and seating system

Moon	70
Torre - Pedina	76

Keir	82-91
Keir Collection	83-87
Keir Table	88-91

Pavé Collection	94-101
Pavé Stones	95,98-101
Pavé Log	96-99

Sistema di sedute / Seating system

Oasi	104
-------------	-----

Librerie / Bookcases

Shiro	110
Tetris	114

Chaise longue

Vis à Vis	120
------------------	-----

Data sheet

*

Section	130-144
----------------	---------

Company

Kreoo, il marmo diventa esperienza e design

Kreoo lega il suo nome alla migliore tradizione italiana nella lavorazione del marmo, che evolve verso un prodotto di design, grazie alla collaborazione di progettisti importanti come Enzo Berti, Marco Piva, Matteo Nunziati e Sebastiano Zilio. Dall'ambiente bagno al living, ai rivestimenti, i complementi e i corpi illuminanti, l'azienda sperimenta la pietra naturale in varie forme e composizioni estetiche, e la arricchisce di altri materiali come metalli, legno o vetro. Il risultato è un linguaggio formale e cromatico affascinante, ricco di ispirazioni, che interpreta le vasche freestanding, i lavabi, i tavoli, i coffee table o ancora le superfici tridimensionali con intarsi o intagli, dalle texture contemporanee ed essenziali, che spingono al limite le potenzialità del marmo fino a riprodurre intrecci simili ai tessuti o a sagomare forme scultoree di grande pregio. Dedicata sia agli ambienti indoor sia outdoor, Kreoo aggiunge alla propria offerta a catalogo la possibilità di realizzare proposte personalizzate, grazie a una filiera produttiva d'eccellenza dove la cura artigianale e la lavorazione manuale costituiscono valori imprescindibili. Il brand, nato nel 2010 dall'esperienza di Decormarmi e forte di una distribuzione internazionale - soprattutto negli Stati Uniti, Europa, Middle East, Russia, India e Oceania - accompagna così grandi progetti internazionali soprattutto nel mondo hospitality e residenziale di lusso.

www.kreoo.com

 @kreodesign

 @kreodesign

 @kreoo

Kreoo: marble becomes experience and design

Kreoo links its name to the best Italian tradition in marble manufacturing, which evolves into a design product thanks to the collaboration of relevant designers such as Enzo Berti, Marco Piva, Matteo Nunziati, and Sebastiano Zilio. From the bathroom and living room to coverings, furnishings, and lighting fixtures, the company works with natural stone in various forms and aesthetic compositions, enriching it with other materials such as metals, wood, and glass. The result is a fascinating and chromatic language, expressed into freestanding bathtubs, washbasins, tables, coffee tables, and three-dimensional inlaid or carved panels. Their contemporary and essential textures bring the potential of marble to the limit, creating weaves similar to fabrics or shaping sculptural figures of outstanding value. Targeting both indoor and outdoor environments, Kreoo adds the possibility of creating customized solutions, thanks to a productive process of excellence, where artisan care and workmanship are essential values. The brand, born in 2010 by the experience of Decormarmi and strong of its international distribution - especially in the United States, Europe, Middle East, Russia, India, and Oceania - leads to major international projects, especially in the world of hospitality and luxury residential.

About the collection

Dalle superfici orizzontali a piccoli complementi, fino ai grandi oggetti attraverso i quali dare dimensione e funzione agli spazi, Kreoo modella gli ambienti living con collezioni di arredi in marmo, caratterizzati da una cifra stilistica contemporanea e dalla valorizzazione della materia attraverso la forma. A firmarle sono importanti designer che hanno lavorato su volumi e dettagli, alleggerendo ora l'immagine della pietra naturale con sagome fluide e spessori ridotti, ora, invece, arricchendola dell'inserimento di dettagli in metallo, legno o vetro di Murano.

Il catalogo comprende tipologie eterogenee: coffee table, sgabelli, importanti tavoli meeting o da pranzo, librerie, sistemi di seduta dedicati ad ambienti indoor e outdoor o ancora per spazi lounge e aree wellness.

Una varietà di prodotti a cui corrispondono altrettanti linguaggi, tutti orientati ad esprimere pienamente il valore della pietra naturale e le sue proprietà, così come le sue venature decorative, attraverso particolari lavorazioni sulle bordature, fresature e incisioni. Le lastre e i blocchi di pietra sono infatti processati attraverso lavorazioni industriali a cui seguono trattamenti manuali, resi possibili da una filiera di eccellenza, che assicura la possibilità di realizzare personalizzazioni sulle soluzioni a catalogo, ideali sia per contesti residenziali sia contract.

From horizontal surfaces to small complements, up to large items that give dimension and function to spaces, Kreoo shapes living spaces with collections of marble furniture, characterized by a contemporary style and by the enhancement of the material through the shape. They are signed by important designers who have worked on volumes and details, lightening the image of natural stone with fluid shapes and reduced thicknesses, and enriching it with the addition of metal, wood or Murano glass details. The catalogue includes heterogeneous typologies: coffee tables, stools, important meeting or dining tables, bookcases, seating systems dedicated to indoor and outdoor environments or even for lounge and wellness areas.

A multitude of products corresponding to as many languages, all oriented to fully express the value of natural stone and its properties, as well as its decorative veining, through special processing on the edges, milling and engravings. Slabs and blocks of stone are in fact subjected to industrial processing followed by manual procedures, thanks to a production line of excellence that ensures the possibility of customizing the solutions in the catalogue, ideal for both residential and contract contexts.

Arcaico

Design by
Enzo Berti



Arcaico

Rigore classico, linguaggio contemporaneo e sperimentazione tecnologica definiscono il progetto Arcaico, una famiglia di tavoli con top tondo o rettangolare in quattro diverse dimensioni disegnata da Enzo Berti. Le gambe, importanti, sono immaginate come cilindri di marmo dalla sezione costante e possono concentrarsi all'estremità di uno dei lati corti, diventando dei contrappesi rispetto al piano, che risulta quasi sospeso. Al di sotto della sua superficie, disponibile in tredici tipologie di marmo o differenti essenze di legno, è collocata una 'trabeazione' metallica che raccorda i supporti in pietra naturale: crea una struttura idealmente analoga a un ponte, tecnica, che contrasta piacevolmente con gli altri componenti della collezione. Arcaico permette di sperimentare con accostamenti di finiture e materiali, per la massima personalizzazione, sia per ambienti residenziali o contract.

Classic rigour, contemporary language and technological experimentation define the Arcaico project, a family of tables with a round or rectangular top in four different sizes designed by Enzo Berti. The legs, important, are conceived as cylinders of marble with a constant section and can also be positioned at the end of one of the short sides, becoming counterbalances to the top, which is almost suspended. Underneath its surface, available in thirteen types of marble or different types of wood, there is a metal "trabeation" that connects the bases in natural stone: it creates a structure that is ideally similar to a bridge, a technique that contrasts nicely with the other components of the collection. Arcaico allows you to experiment with combinations of finishes and materials, for maximum customization, whether for residential or contract environments.

Cat. Tavolo / Table /
Design by **Enzo Berti** /
Year 14-18

★ Data sheet 130











Ellenico

→
Design by
Enzo Berti



Ellenico

Sei setti slanciati in marmo pieno, con una sezione ellissoidale allungata, creano la base del tavolo Ellenico disegnato da Enzo Berti.

Hanno orientamenti diversi: sembrano ruotati intorno a un asse centrale e generano un'estetica scultorea e allo stesso tempo dinamica, mentre la loro forma enfatizza le naturali sfumature del marmo. Culminano con un piccolo blocco cubico di marmo, un capitello contemporaneo, che li raccorda all'architrave centrale, realizzata in acciaio e proposta in varie finiture e colorazioni. Il piano ovale, lavorato su tutto il bordo per renderlo più leggero, poggia su questa sottile struttura e si distanzia rispetto alle gambe: sembra quasi sospeso e consegna un'immagine leggera, curata in ogni dettaglio. Ellenico è disponibile in una dimensione (240x120cm) e in sette tipologie di marmo.

Six slender solid marble partitions with an ellipsoidal cross-section create the base of the Ellenico table, designed by Enzo Berti. They can be freely arranged in different orientations: in fact, they rotate around their central axis and generate a sculptural yet dynamic aesthetic, while their shape emphasises the natural nuances of the marble. They are crowned by a small cubic block of marble, a contemporary capital, which anchors them to the central architrave, made of steel and available in various finishes and colours. The oval top, which is shaped along the entire edge to make it look lighter, is placed on the structure and stands apart from the legs: it seems as if it is floating, giving a light image, with great attention to each detail. Ellenico is available in one size (240x120 cm) and in seven types of marble.

Cat. Tavolo / Table /
Design by **Enzo Berti** /
Year 22

★ Data sheet 131





Pluvio

Design by
Matteo Nunziati



Pluvio

La struttura metallica geometrica ed essenziale, in finitura bronzo dorato, scuro o laccato nero opaco, incornicia il top in marmo nel tavolo Pluvio disegnato da Matteo Nunziati e ne suggerisce uno straordinario gioco di antitesi. Il piano circolare ha infatti un diametro importante e la sua forma è enfatizzata dalla particolare lavorazione della superficie, ondulata, che plasma nella pietra naturale un effetto increspato mai costante, analoga a quella che si ottiene nell'acqua. Ne risulta un'estetica liquida, scolpita nella materia (sei le tipologie di marmo disponibili a catalogo) e resa possibile dai processi di lavorazione, che assicura allo stesso tempo la funzionalità del prodotto, ideale come tavolo da pranzo o meeting. Il basamento è sempre contornato dal profilo metallico e si configura come un disco, sempre in marmo ma con finitura liscia, parallelo al top.

The geometric and essential metal structure, in golden bronze, dark bronze or matt black lacquered finish, frames the marble top of the Pluvio table designed by Matteo Nunziati and hints at an extraordinary game of antitheses. In fact, the round top has an important diameter and its shape is emphasized by the particular processing of the surface, wavy, which moulds in the natural stone a rippled effect that is never steady, similar to the one created by water. The result is a liquid aesthetic, sculpted in the material (six types of marble are available in the catalogue) thanks to the manufacturing processes, which at the same time ensures the functionality of the product, ideal as a dining or meeting table. The base is again bordered by the metal profile and is configured as a disc, again in marble but with a smooth finish, parallel to the top.



Cat. Tavolo / Table /
Design by **Matteo Nunziati** /
Year 20

★ Data sheet 131

Torre Maxi

Design by
Enzo Berti

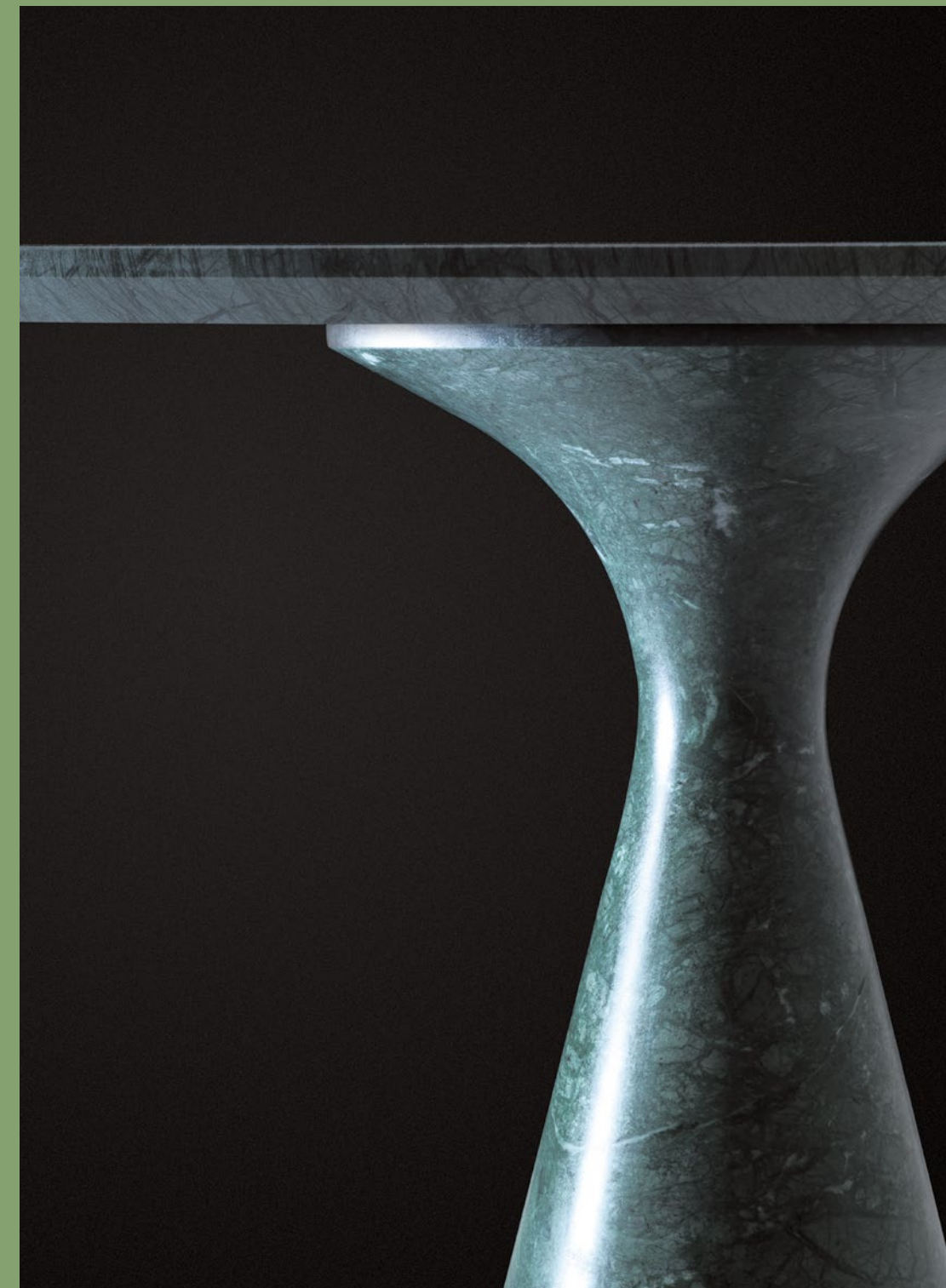

Torre Maxi

Il tavolo Torre Maxi, disegnato da Enzo Berti, trasforma la solidità del marmo e la sua durezza intrinseca in un oggetto sinuoso, scultoreo, fatto da volumi equilibrati e raffinati.

Proposto in una sola variante dimensionale, è definito da un piano circolare segnato da un bordo sottile, poi inclinato e lavorato a 45° per dare un'immagine di grande leggerezza. A sostenerlo è una base realizzata a partire da un unico blocco di pietra naturale, rastremata, con un doppio effetto conico che enfatizza le venature naturali del materiale, proposto in otto possibili varianti a catalogo. Torre Maxi può essere impiegato per arredare una zona living residenziale o come prezioso tavolo meeting.

The Torre Maxi table, designed by Enzo Berti, transforms the hardness of marble and its intrinsic solidity into a sinuous, sculptural object made of balanced, refined volumes.

Proposed in a single size model, it is composed of a round top characterized by a thin edge, then inclined and worked at 45° to give an impression of great lightness. It is sustained by a base made from a single block of natural stone, tapered, with a double conical effect that emphasizes the natural veining of the material, available in eight possible variations in the catalogue.

Torre Maxi can be used in a residential living room or as a precious meeting table.



Cat. Tavolo / Table /
Design by **Enzo Berti** /
Year 10-18

* Data sheet 137



Kalende Collection

Kalende Maxi
Kalende Medium

→
Design by
Enzo Berti



Table and coffee table /
Tavolo e tavolino

Kalende Collection

Tre diversi layer creano un elegante gioco di sovrapposizioni nella famiglia di tavoli Kalende disegnata da Enzo Berti. Una sottile piastra metallica costituisce il primo 'livello' - a quota pavimento - e definisce l'elegante basamento orizzontale che permette la stabilità del prodotto. Si appoggia su questa, in modo perpendicolare, l'importante elemento in marmo che sostiene il piano e si estende per tutta la lunghezza dello stesso, in corrispondenza della mezzeria: ha una sezione poligonale, rastremata alle due estremità, ed è valorizzata dall'inserimento di una sottile linea centrale, sempre metallica, che funge allo stesso tempo da motivo decorativo e telaio strutturale. Il top può essere rettangolare o circolare, in diverse dimensioni, e si appoggia trasversalmente rispetto alla base, creando una suggestione di grande equilibrio e leggerezza. Disponibile in otto tipologie di marmo, Kalende può essere impiegato come tavolo dining o meeting.

Three different layers create an elegant game of overlays in the Kalende family of tables designed by Enzo Berti. A thin metal plate constitutes the first 'layer' - at floor level - and defines the elegant horizontal base that gives stability to the product. The important marble element that supports the top is placed perpendicularly on this base and extends along the entire length of the top, in correspondence with the middle: it has a polygonal section, tapered at both ends, and is enhanced by the insertion of a thin central line, also metal, which acts as both a decorative motif and a structural frame. The top can be rectangular or circular, in different sizes, and stands transversally to the base, combining great balance and lightness. Available in eight types of marble, Kalende can be used as a dining or meeting table.

Cat. Tavolo e tavolino /
Table and coffee table /
Design by **Enzo Berti** /
Year 22

★ Data sheet 132

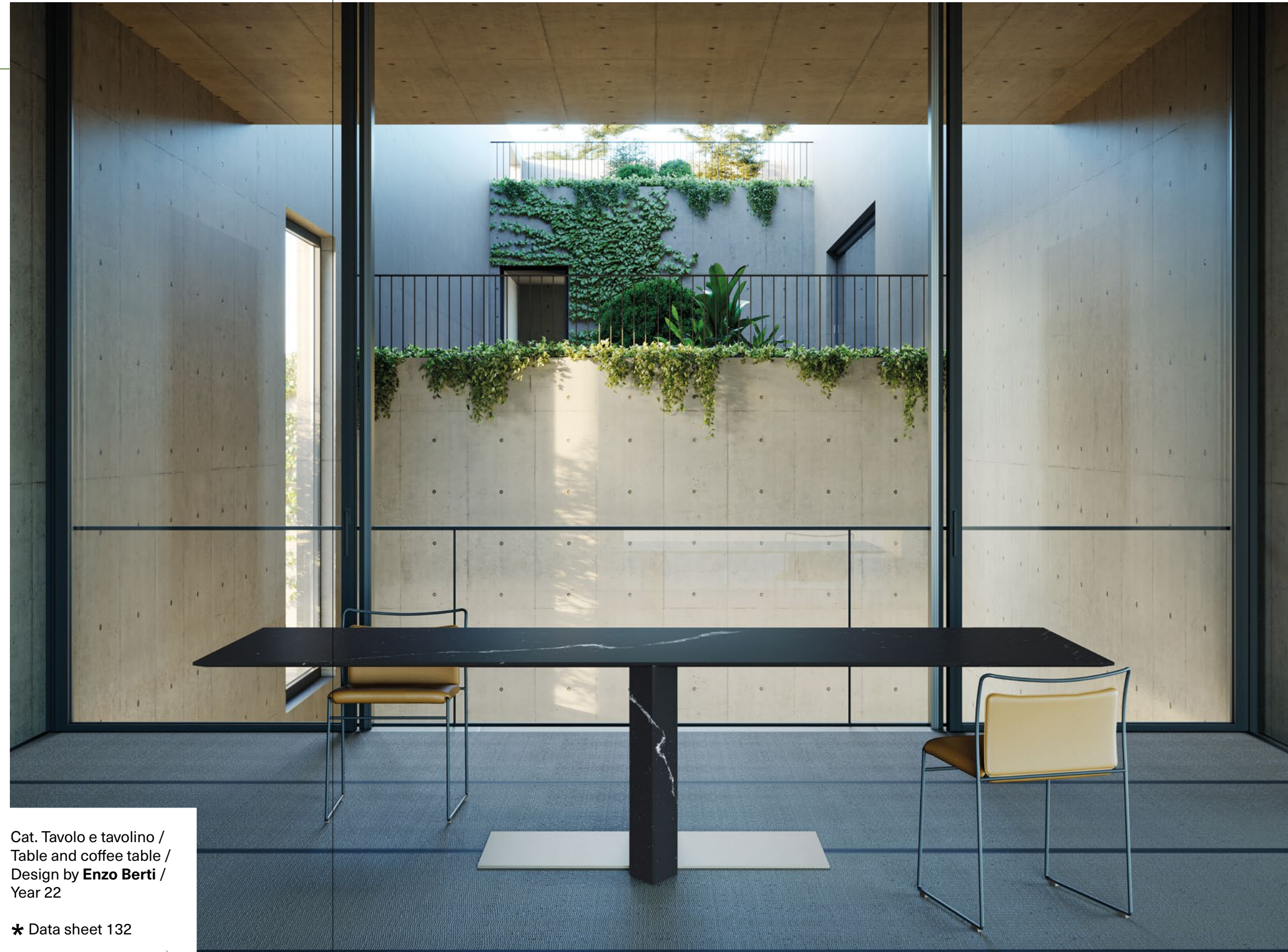

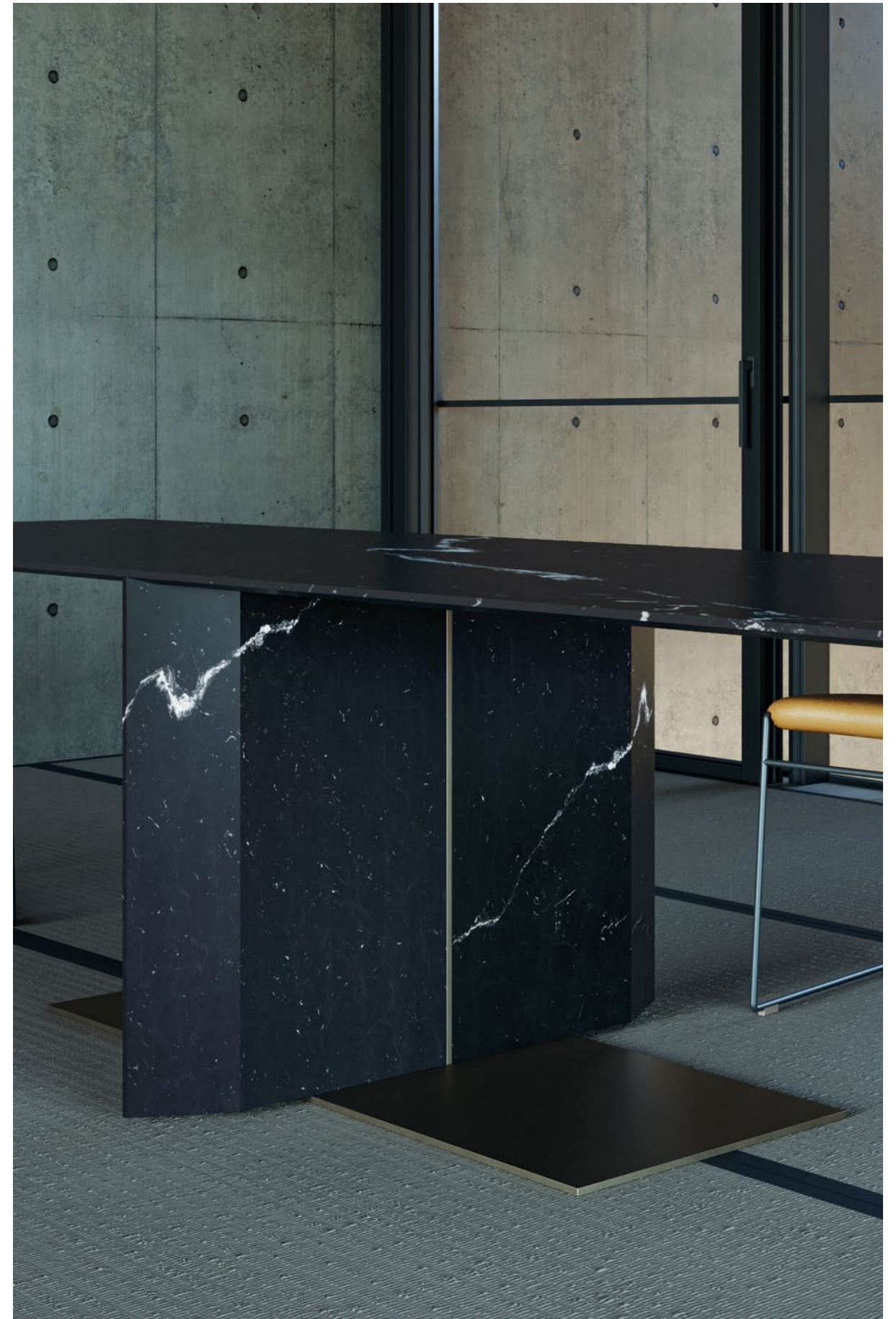

More

Design by
Marco Spatti



Table and coffee table /
Tavolo e tavolino

More

La proiezione della struttura sul piano - una sottile croce dai profili e dai raccordi morbidi - definisce la cifra estetica di More, la collezione di tavoli rotondi e ovali, in diverse dimensioni, firmata da Marco Spatti.

A formare la base sono lastre di pietra naturale poste in verticale e raccordate tra loro, la cui forma emerge quindi sulla superficie del top, che può essere realizzato nella medesima tipologia di marmo - selezionabile tra le otto proposte a catalogo - o a contrasto. Proposto anche con una sottile lamina di rivestimento in bronzo scuro, il segno decorativo genera ulteriori trame sul piano: ogni suo braccio si allunga in una semplice linea, un taglio che si estende sino a toccare il bordo del piano, dove si crea un'elegante smussatura. Ne risulta la possibilità di lavorare con lastre di marmo più piccole, riducendo così lo spreco di materiale, mentre l'architettura del prodotto consente di dar vita a tavoli grandi, irrealizzabili invece a partire da un'unica superficie di marmo. Nella versione ovale, ideale anche per contesti di sale riunioni, la base di More è infine raddoppiata e il top, ellittico, si struttura idealmente sui due 'fuochi'.

The projection of the structure on the top - a thin cross with soft profiles and corners - is the main aesthetic feature of More, the collection of round and oval tables in different sizes designed by Marco Spatti. The base is composed of vertically connected slabs of natural stone, whose shape emerges on the surface of the top, which can be realized in the same type of marble - selectable among the eight proposed in the catalogue - or in contrast. Also available with a dark bronze covering foil, the decorative motif provides an additional texture on the top: each of its branches extends into a simple line to the edge of the top, where an elegant bevel is generated. The result is the possibility of working with smaller slabs of marble, thus reducing the waste of material, while the architecture of the product allows the creation of large tables, which would be impossible to produce from a single slab of marble.

In the oval version, ideal also for meeting rooms, the base of More is doubled and the elliptical top is perfectly structured in two "focuses".

Cat. Tavolo e tavolino /
Table and coffee table /
Design by **Marco Spatti** /
Year 22

★ Data sheet 133





→
Table - **More**
Coffee table - **Torre**
Seating system - **Pavé Log**
Covering - **Folium**

Jackie

Design by
Sebastiano Zilio

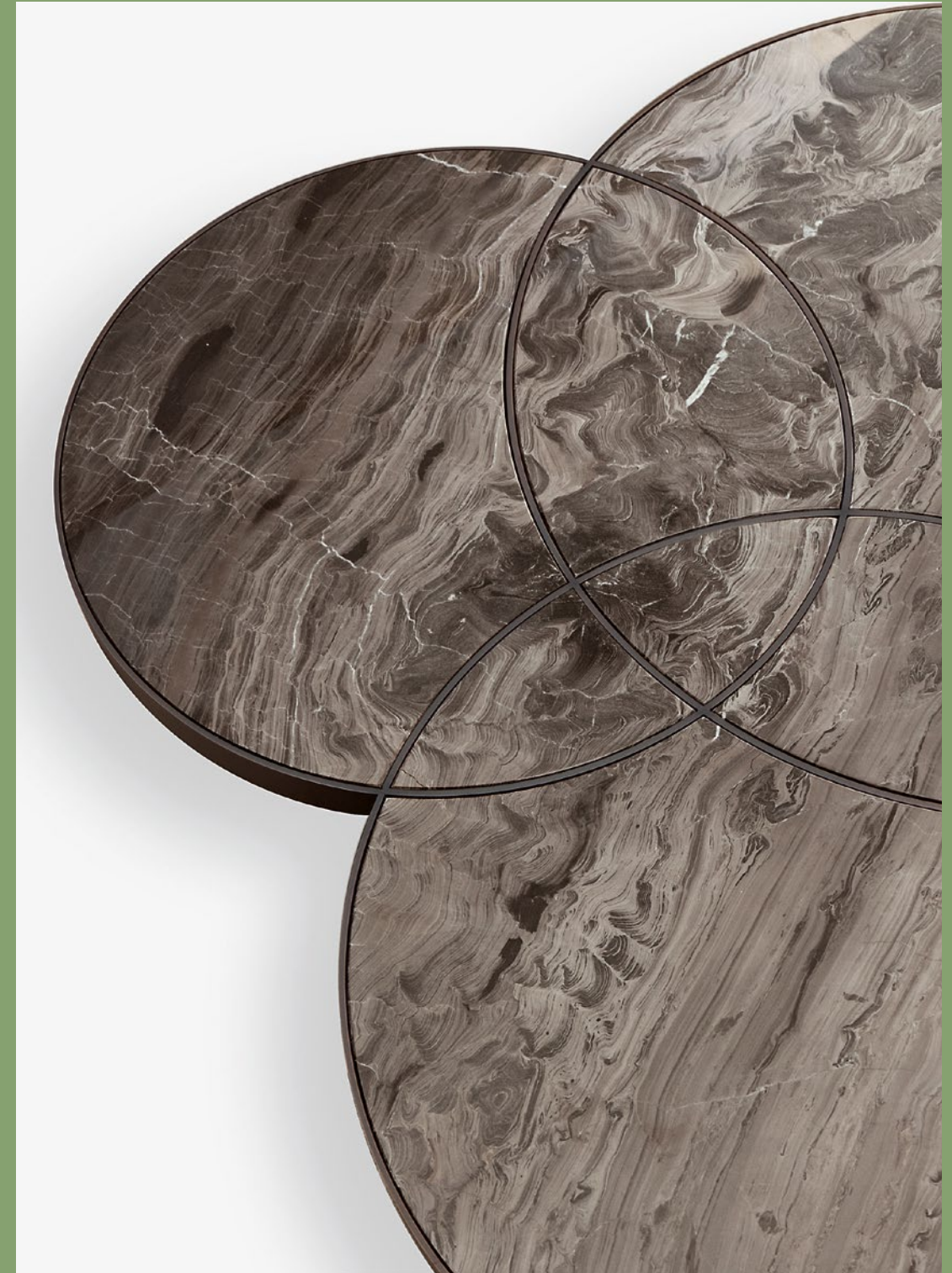

Jackie

Tre elementi circolari perfetti, di diametro differenti, si intersecano l'uno con l'altro per creare il piano, articolato, del tavolino Jackie, proposto in una sola variante dimensionale e disegnato da Sebastiano Zilio. Il perimetro di ciascuna forma è visibile sul top, inciso nella preziosa superficie in marmo che può essere selezionato tra dieci possibili tipologie di materiale; a definirne invece la cornice è un profilo metallico in finitura bronzo dorato, rosa e scuro, dalla quale si sviluppano i tre sottili supporti che costituiscono la struttura. Le scanalature sul piano in pietra naturale, ricavato da un'unica lastra, diventano un motivo decorativo del design di Jackie e sono ulteriormente enfatizzate dalle venature naturali del marmo.

Three perfect round elements, of different diameters, intersect one against the other to create the elaborate top of the Jackie table, available in one size only and designed by Sebastiano Zilio. The perimeter of each shape is visible on the top, engraved in the precious marble surface that can be selected among ten possible types of material; its frame, by contrast, is defined by a metal profile in golden, pink and dark bronze finish, from which extend the three thin supports that compose the structure. The grooves on the natural stone top, cut from a single slab, become a decorative motif of Jackie's design and are further emphasized by the natural veining of the marble.



Cat. Tavolino / Coffee table
Design by **Sebastiano Zilio** /
Year 18

★ Data sheet 134

John

Design by
Sebastiano Zilio



John

Tre elementi quadrati perfetti, con diverse grandezze, si intersecano l'uno con l'altro per creare il piano del tavolino John, proposto in una sola variante dimensionale e disegnato da Sebastiano Zilio. Il perimetro di ciascuna forma è visibile sul top, inciso nella preziosa superficie in marmo che può essere selezionato tra undici possibili tipologie di materiale; a definirne invece la cornice è un profilo metallico in finitura bronzo dorato, rosa e scuro, dalla quale si sviluppano i tre sottili supporti che costituiscono la struttura. Le scanalature sul piano in pietra naturale, ricavato da un'unica lastra, diventano un motivo decorativo del design di John e sono ulteriormente enfatizzate dalle venature naturali del marmo.

Three perfect squared elements, with different sizes, intersect each other to create the top of the John coffee table, proposed in only one size variant and designed by Sebastiano Zilio. The edge of each of the three volumes is visible on the top, engraved in the precious marble surface that can be selected from eleven possible types of material; defining the frame is a metal profile in a golden, pink and dark bronze finish, from which develop the three thin supports that compose the structure. The grooves on the natural stone top, cut from a single slab, become a decorative motif of John's design and are further emphasized by the natural veining of the marble.



Cat. Tavolino / Coffee table
Design by **Sebastiano Zilio** /
Year 18

★ Data sheet 134

Nodo

Nodo Mini
Nodo Medium
Nodo Maxi
Nodo Consolle

→
Design by
Enzo Berti



Nodo

Le linee geometriche, l'essenzialità del disegno e il concetto di modularità definiscono il programma di arredo Nodo, la famiglia versatile di coffee table e piani di appoggio disegnata da Enzo Berti. La struttura è molto esile: si compone di sottili elementi metallici, a sezione quadrata e finitura bronzo dorato, rosa o scuro, che definiscono una griglia leggerissima di incastri entro i quali si inserisce il top. Il piano ha profilo quadrato o rettangolare ed è proposto in numerose tipologie di marmo: nella versione con Onice Tramonto o altri materiali dalla forte connotazione cromatica, diventa un oggetto fortemente decorativo e attenua il suo codice minimale. Nodo è disponibile in diverse varianti dimensionali e può essere impiegato in progetti residenziali, hospitality, retail e office.

The geometric lines, the essential design and the concept of modularity are the main features of Nodo, the versatile family of coffee tables and vanity tops designed by Enzo Berti. The structure is very lean: it is composed of thin metal elements with a square section and a golden, pink or dark bronze finish, which define a very light grid of joints into which the top is placed. The top has a square or rectangular shape and is available in numerous types of marble: in the version with Onyx Tramonto or other materials with a marked chromatic connotation, it becomes a highly decorative element and attenuates its minimalist code. Nodo is available in various sizes and can be used in residential, hospitality, retail and office projects.



Cat. Tavolino / Coffee table
Design by **Enzo Berti** /
Year 18

* Data sheet 135



Tangram Mini

Design by
Enzo Berti



Tangram Mini

Un intreccio di piani di dimensioni e materiali diversi, perpendicolari e sfalsati tra loro, compone la figura astratta che definisce la base di tavolini Tangram, disegnati da Enzo Berti. Sono lastre di marmo, selezionabili tra le diverse tipologie a catalogo, accostate a tavole rettangolari in varie essenze di legno: il loro gioco di intersezioni, che culmina con un disegno a croce, è perfettamente visibile dal top, realizzato in vetro. Tangram è ideale per l'arredo di spazi residenziali e contract.

An interplay of tops of different sizes and materials, perpendicular and staggered, creates the abstract figure that defines the base of the Tangram coffee table, designed by Enzo Berti. It is made of marble, selectable from the different types in the catalogue, combined with rectangular boards in different types of wood: their game of intersections, culminating in a cross design, is perfectly visible from the top, made of glass. Tangram is ideal for furnishing residential and contract spaces.

Cat. Tavolino / Coffee table
Design by **Enzo Berti** /
Year 16

* Data sheet 136



coffee table / tangram mini



coffee table / tangram mini



Moon

Design by
Enzo Berti



Coffee table and seating system /
Tavolino e sistema di sedute

Moon

Ideati per essere allo stesso tempo coffee table o sgabelli, gli elementi della collezione Moon sono caratterizzati da un piano circolare, con diametro 50 cm, trattato sia come una superficie piana oppure leggermente scavata al centro, analogamente a un cratere lunare. Il top della seduta rievoca infatti l'elemento astrale e perde il profilo completo della circonferenza a favore di una configurazione a 'tre quarti', che permette così la perfetta combinazione con il tavolino e la creazione di sequenze personalizzate, ideali per arredare un'area living, lounge o ancora la zona notte. Disegnato da Enzo Berti, Moon ha un top disponibile in tre essenze di legno oppure in undici differenti tipologie di marmo; lo sostiene una struttura metallica formata da quattro supporti verticali, leggermente inclinati, uniti ad un basamento sempre circolare nella medesima finitura.

Designed to be at both coffee tables and stools, the elements of the Moon collection are defined by a circular top, with a diameter of 50 cm, which is either processed as a flat surface or slightly hollowed out in the middle, resembling a lunar crater. In fact, the top of the seat evokes the astral element and loses the complete profile of the circumference in favour of a 'three-quarter' configuration, which thus allows the perfect combination with the coffee table and the creation of customized sequences, ideal for furnishing a living area, lounge or even the bedroom suite. Designed by Enzo Berti, Moon has a top available in three types of wood or eleven different types of marble; it is held up by a metal base made up of four vertical supports, slightly inclined, joined to a circular base in the same finish.

Cat. Tavolino e sistema
di sedute / Coffee table
and seating system /
Design by **Enzo Berti** /
Year 14

★ Data sheet 138



coffee table and seating system /
moon



Torre - Pedina

Design by
Enzo Berti

coffee table and seating system /
torre - pedina



Coffee table and seating system /
Tavolino e sistema di sedute

Torre - Pedina

L'idea di realizzare una collezione di oggetti di arredo - sedute e coffee table - in cui la durezza intrinseca del marmo venga mitigata dalla sinuosità della forma suggerisce la famiglia Pedina-Torre disegnata da Enzo Berti. Gli elementi rievocano la sagoma del celebre gioco da tavolo, con basi dalle sezioni coniche rastremate che enfatizzano la materia naturale, selezionabile tra otto tipologie a catalogo. Circolare, il loro piano è caratterizzato da una particolare lavorazione del bordo, a rilievo, che è disponibile in due dimensioni nella linea di tavolini Torre e in tre varianti per Pedina. Questo ha un top smussato, per garantire la migliore ergonomia di seduta, e il suo contorno può essere realizzato con un marmo a contrasto, per un piacevole effetto decorativo.

The idea of creating a collection of interior design objects - seats and coffee tables - in which the intrinsic hardness of marble is mitigated by the sinuosity of the shape has led the Pedina-Torre family designed by Enzo Berti. The elements remind the silhouette of the famous board game, with bases with tapered conical sections that emphasize the natural material, which can be selected from eight types in the catalogue. The top is circular and features a special, embossed edge that is available in two sizes in the Torre table line and in three variations for Pedina. It has a bevelled top, to ensure the best ergonomics also for sitting, and its rim can be made with a contrasting marble, for a beautiful decorative effect.

Cat. Tavolino e sistema
di sedute / Coffee table
and seating system/
Design by **Enzo Berti** /
Year 10-18

★ Data sheet 137





Keir

Keir Collection
Keir Table



Design by
Enzo Berti

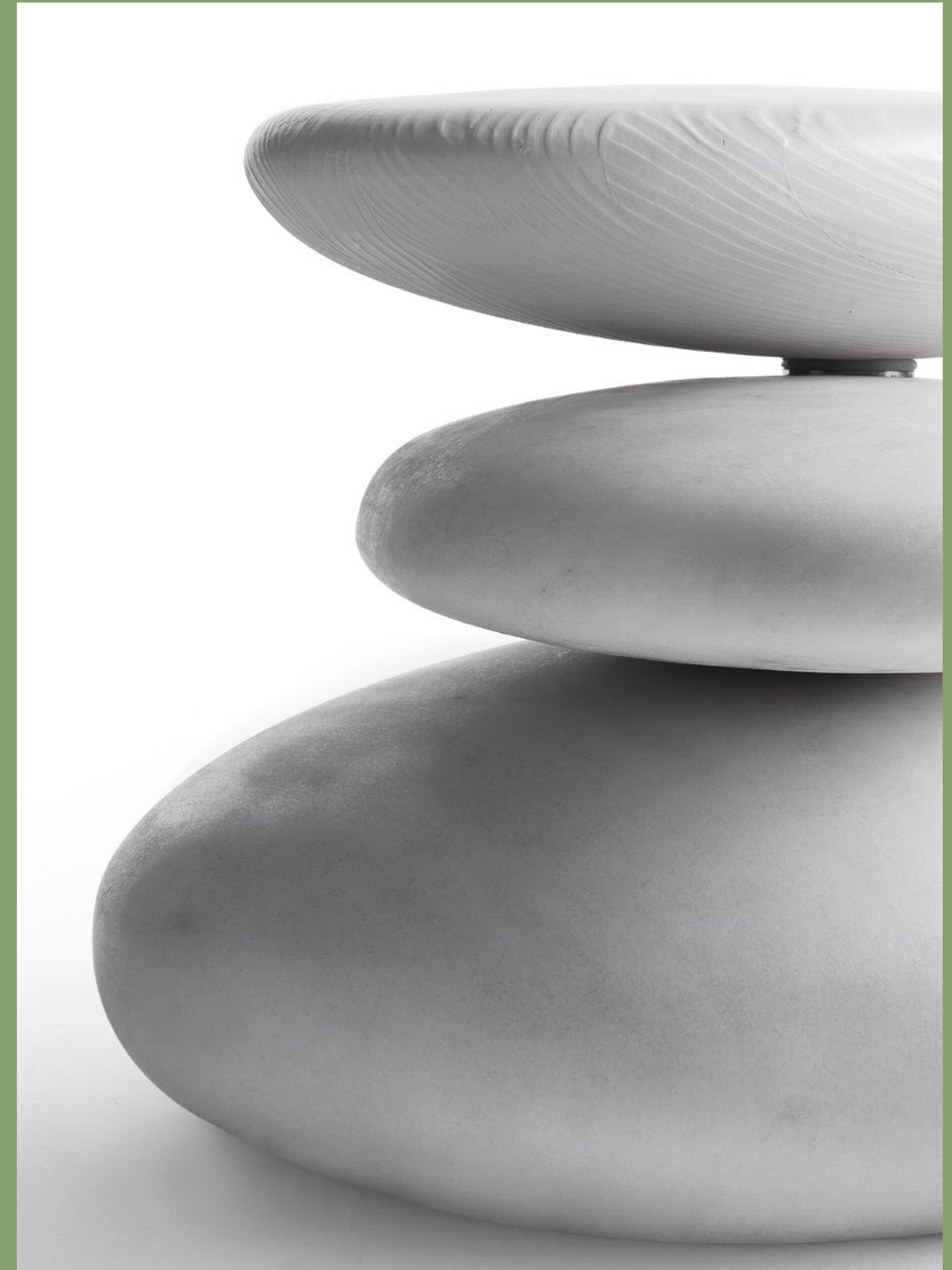

Coffee table and seating system /
Tavolino e sistema di sedute

Keir

Il marmo è lavorato come se fosse un ciottolo modellato e levigato dall'acqua nella collezione Keir, che comprende coffee table in differenti forme e configurazioni e sedute liberamente posizionabili nello spazio, in indoor o outdoor. Associato al legno, sagomato con la stessa morbidezza delle forme, può dare vita a una composizione in verticale di due o tre elementi, sfalsati e fissati tra loro grazie a una struttura metallica interna che ne garantisce la stabilità. Firmato da Enzo Berti, il design di Keir è arricchito dal gioco di spessori e profili curvati di ciascuna parte, personalizzabile in otto tipologie di marmo e due essenze di legno; il tavolino, infine, può essere completato con un top in cristallo circolare o quadrato, nelle due versioni dalla dimensione importante.

Marble is worked as if it were a pebble shaped and honed by water in the Keir collection, which includes coffee tables in different shapes and configurations and seats that can be freely positioned in the space, either indoors or outdoors. Combined with wood, shaped with the same soft lines, it can create a vertical composition of two or three elements, which can be arranged in a different direction and fixed together thanks to an internal metal structure that guarantees stability. Designed by Enzo Berti, the design of Keir is enriched by the play of thicknesses and curved profiles of each part, customizable in eight types of marble and two types of wood; finally, the table can be completed with a circular or square crystal top, in the two versions of important dimensions.

Cat. Tavolino e sistema
di sedute / Coffee table
and seating system /
Design by **Enzo Berti** /
Year 22

* Data sheet 138-139





coffee table and seating system /
pavé stones and keir collection



coffee table and seating system /
pavé stones and keir collection



coffee table and seating system /
pavé stones, keir table and keir collection

coffee table and seating system /
pavé stones, keir table and keir collection



coffee table and seating system /
pavé stones, keir table and keir collection

coffee table and seating system /
pavé stones, keir table and keir collection



Pavé Collection

Pavé Stones
Pavé Log



Design by
Enzo Berti



Coffee table and seating system /
Tavolino e sistema di sedute

Pavé Collection

Si declina nelle tre versioni Pavé Stones, Pavé Log e Pavé Drink la collezione di sedute e coffee table per indoor e outdoor disegnata da Enzo Berti e ispirata all'azione che il fluire dell'acqua produce nel tempo sulle pietre, levigandole. Il marmo, selezionabile tra le dieci tipologie a catalogo, prende quindi la configurazione di un ciottolo sapientemente modellato grazie all'utilizzo di processi industriali e artigianali, e si accosta al legno, ugualmente trattato, con profili morbidi e sagome ovali. Pavé Stone nasce dall'accostamento di due elementi, uno in pietra naturale e uno in larice bianco o invecchiato o ancora laccato in colorazioni personalizzabili, uniti tra loro da un elemento metallico a fissaggio; in Pavé Drink il 'ciottolo', invece, funge da base in cui si inserisce un tubolare metallico che sostiene un top circolare per realizzare un tavolino. Pavé Log si configura infine come una panca, realizzata in legno e coperta anche con cuoio naturale, proposta in tre varianti dimensionali e ideale per arredare una zona lounge o ambienti museali.

Pavé Stones, Pavé Log and Pavé Drink are the three versions of the collection of seats and coffee tables for indoors and outdoors designed by Enzo Berti and inspired by the action that the running water produces over time on the stones, smoothing them. The marble, which can be selected from the ten types in the catalogue, is shaped like a pebble, skilfully modelled through the use of industrial and artisanal processes, and is combined with wood, also treated, with soft profiles and oval shapes. Pavé Stone is the result of the combination of two elements, one in natural stone and one in white or aged larch wood, or lacquered in customizable colours, joined together by a metal fixing element; in Pavé Drink, instead, the 'pebble' acts as a base into which a metal tube is inserted, supporting a circular top to create a small coffee table. Finally, Pavé Log is a bench, made of wood that can also be covered with natural leather, available in three different sizes and ideal for furnishing a lounge area or a museum.

Cat. Tavolino e sistema di sedute / Coffee table and seating system / Design by **Enzo Berti** / Year 10

* Data sheet 140



coffee table and seating system /
pavé log

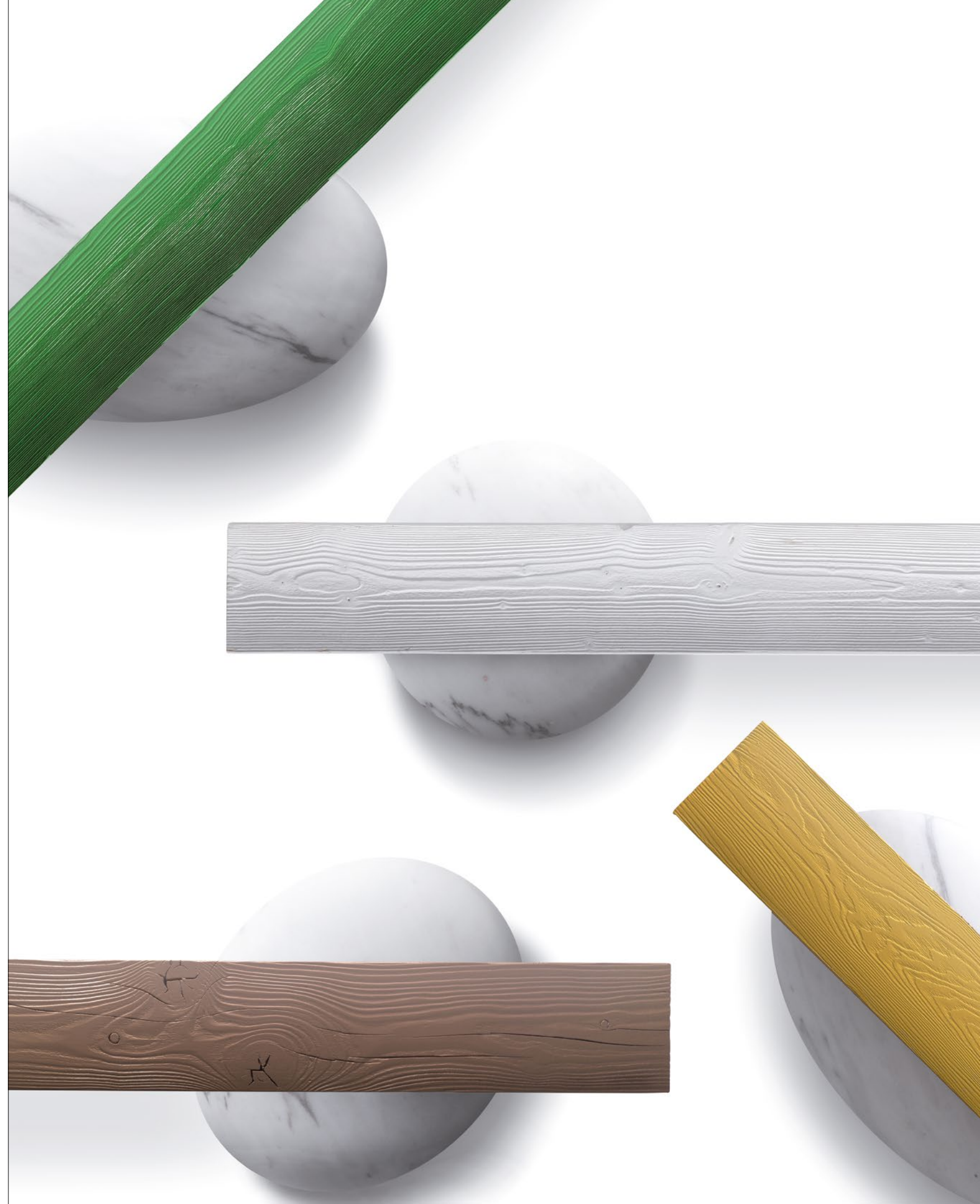

coffee table and seating system /
pavé stones, pavé log and keir collection

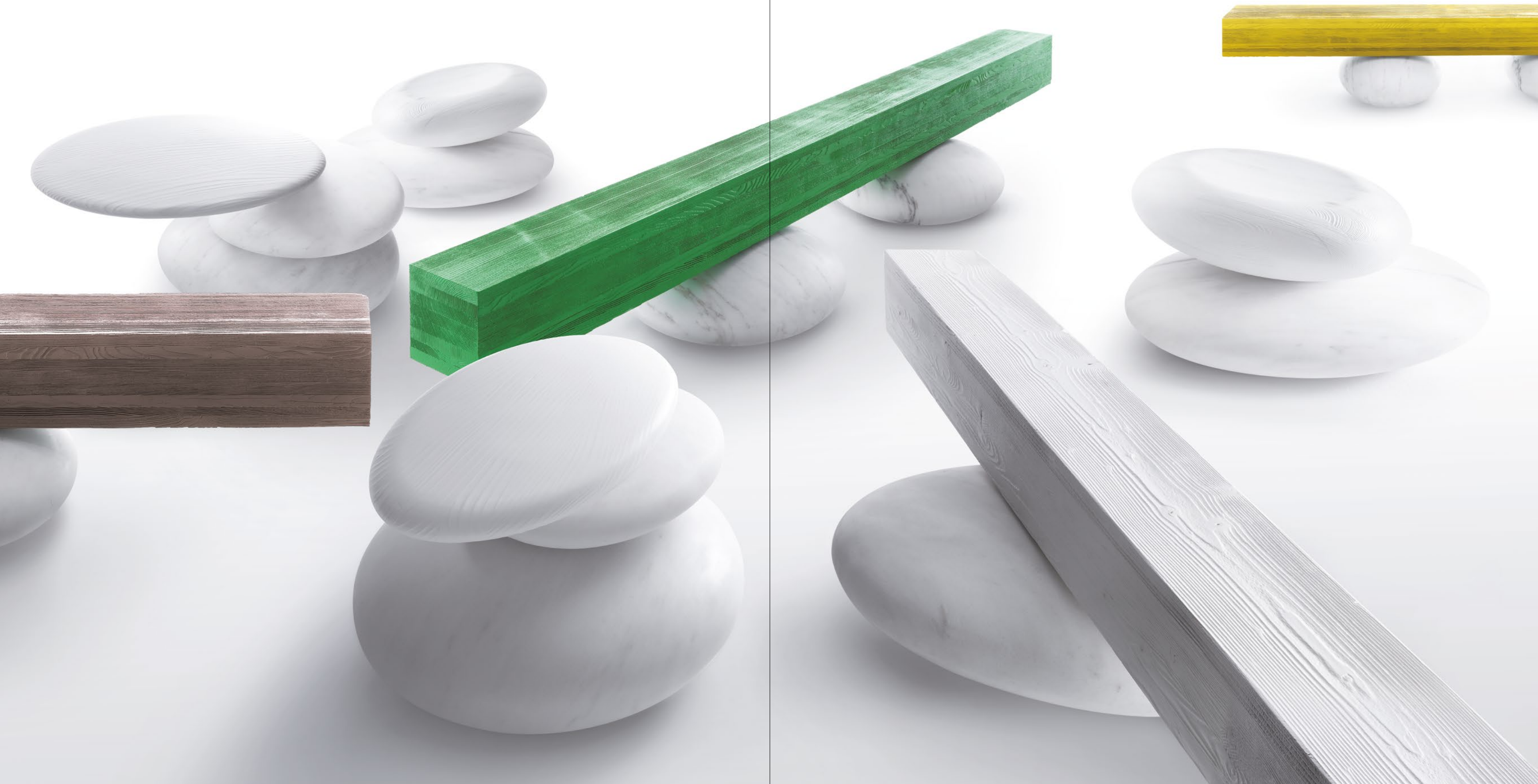

coffee table and seating system /
pavé stones, pavé log and keir collection



Oasi

→
Design by
Enzo Berti



Oasi

Oasi nasce dalla sovrapposizione di più strati orizzontali di pietra naturale - travertino paglierino, travertino noce o bianco carrara - che costituiscono dei layer permeabili e dalla forma organica, di dimensioni diverse, fissati tra loro da tubolari metallici disposti in verticale. La superficie superiore, alla quota di circa 40 cm, è invece in larice invecchiato: sagomata, offre un comodo elemento di seduta, ideale per arredare zone lounge o outdoor. In tre diverse conformazioni, che possono essere accostate, Oasi crea delle vere e proprie isole di sosta, grazie alle sagome fluide dei profili che rievocano la struttura degli atolli.

Oasi is the result of the superimposition of several horizontal layers of natural stone – travertino paglierino, travertino noce or bianco carrara - which create permeable and organic-shaped layers of different sizes, fixed together by vertically arranged metal tubes. The upper surface, at a height of about 40cm, is made of aged larch: thanks to its shape, it provides a comfortable seating element, ideal for furnishing lounge or outdoor areas. In three different formats, which can be combined, Oasi creates real rest areas, thanks to the fluid outlines of the profiles that evoke the structure of atolls.

Cat. Sistema di sedute /
Seating system /
Design by **Enzo Berti** /
Year 10

★ Data sheet 141





Shiro

→
Design by
Enzo Berti



Shiro

Arredo da utilizzare in modalità freestanding oppure a parete, Shiro è un sistema libreria modulare il cui disegno nasce da un accurato studio degli spessori e dall'utilizzo di due materiali a contrasto. La sua estetica essenziale è il risultato dell'accostamento di piani orizzontali, marcati, realizzati in legno di larice in differenti finiture, entro i quali si innestano, perpendicolarmente, lastre di marmo più sottili con funzione allo stesso tempo strutturale e di partizione. Il marmo, in dodici tipologie possibili, realizza anche la superficie verticale che può essere posizionata in corrispondenza della mezzeria, nella versione freestanding, oppure come chiusura del mobile. I due lati corti risultano invece aperti e alleggeriscono ulteriormente l'immagine della collezione, firmata da Enzo Berti.

Shiro is a modular bookcase system that can be used in freestanding or wall-mounted mode. Its design is achieved through an accurate study of thicknesses and the use of two contrasting materials. Its essential aesthetics is the result of the combination of distinctive horizontal shelves made of larch wood in different finishes, within which thinner marble slabs are inserted perpendicularly, with a structural and dividing function at the same time. The marble, available in twelve possible types, also creates the vertical side that can be set in the middle, in the freestanding version, or as a closure of the module. The two short sides are instead open and further lighten the image of the system, designed by Enzo Berti.

Cat. Librerie / Bookcases
Design by **Enzo Berti** /
Year 12

★ Data sheet 142



Tetris

Design by
Matteo Nunziati

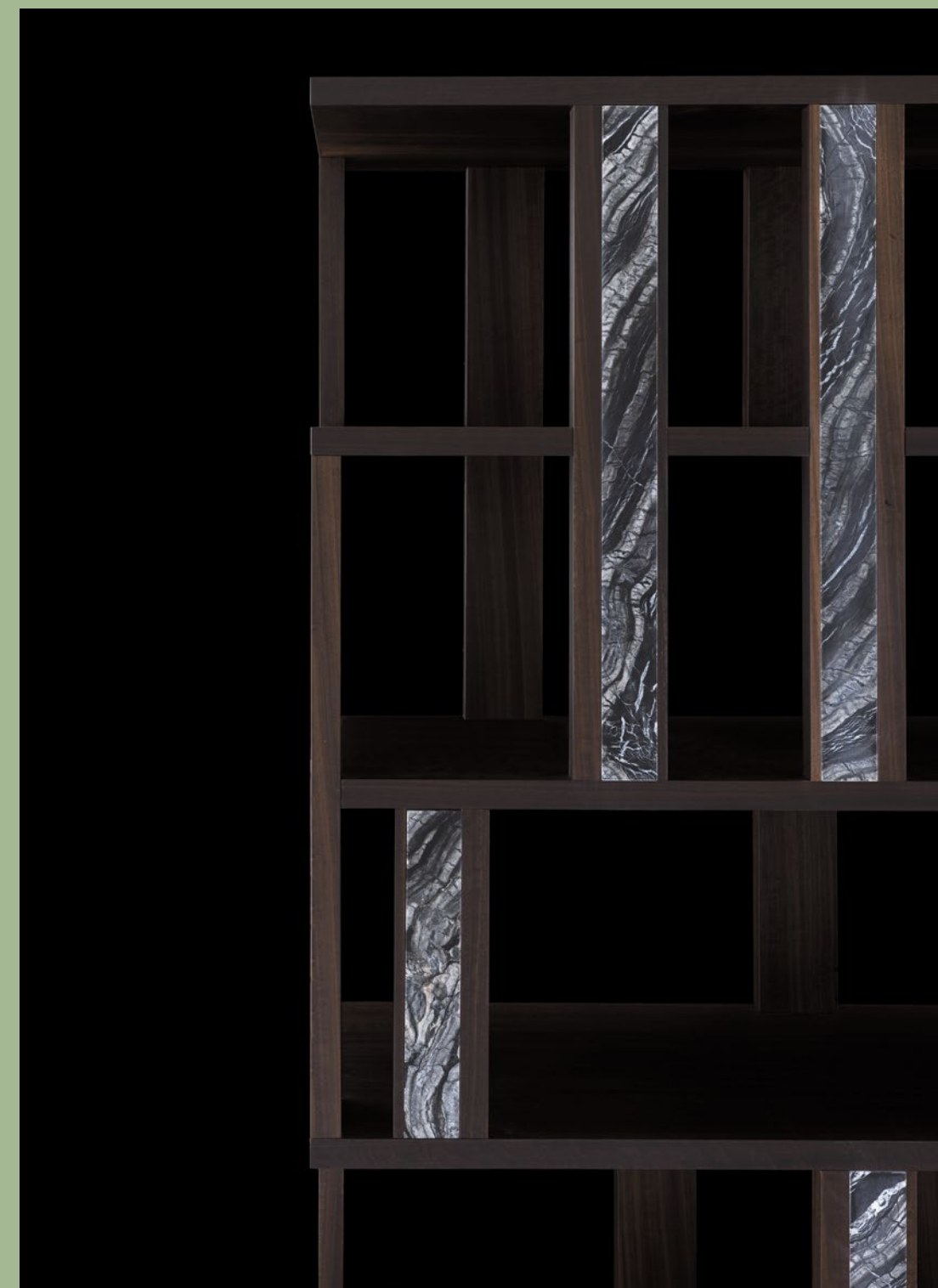

Tetris

Una composizione continua e potenzialmente infinita di elementi si arricchisce di una dualità materica nella libreria Tetris disegnata da Matteo Nunziati. Il mobile si compone di piani orizzontali in legno, equidistanti tra loro, uniti da listelli sempre in essenza legno con un prezioso inserto di marmo, che uniscono in altezza uno o due mensole e disegnano un pattern mai ripetitivo. I profili laterali si perdono e non esiste un perimetro definito in questo gioco essenziale di parti, che condividono il medesimo spessore, sia per le superfici orizzontali sia verticali. Tetris è disponibile in due varianti dimensionali, con struttura in noce, larice bianco o eucalipto frisé e fasce in marmo personalizzabili in uno degli otto materiali a catalogo, e può arredare ambienti ufficio, living o hospitality.

A continuous and potentially infinite composition of elements is enriched by a material duality in the Tetris bookcase designed by Matteo Nunziati. The structure consists of horizontal wooden shelves, equally spaced, joined by wooden strips with a precious marble insert, which connect one or two shelves in height and draw a pattern that is never repetitive. The side profiles are fading and there is no defined perimeter in this essential game of parts which share the same thickness, both for horizontal and vertical surfaces. Tetris is available in two sizes, with a structure available in walnut, white larch or eucalyptus frisé and marble strips that can be customized in one of the eight materials in the catalogue, and can be used in office, living or hospitality environments.

Cat. Librerie / Bookcases /
Design by **Matteo Nunziati** /
Year 22

★ Data sheet 143



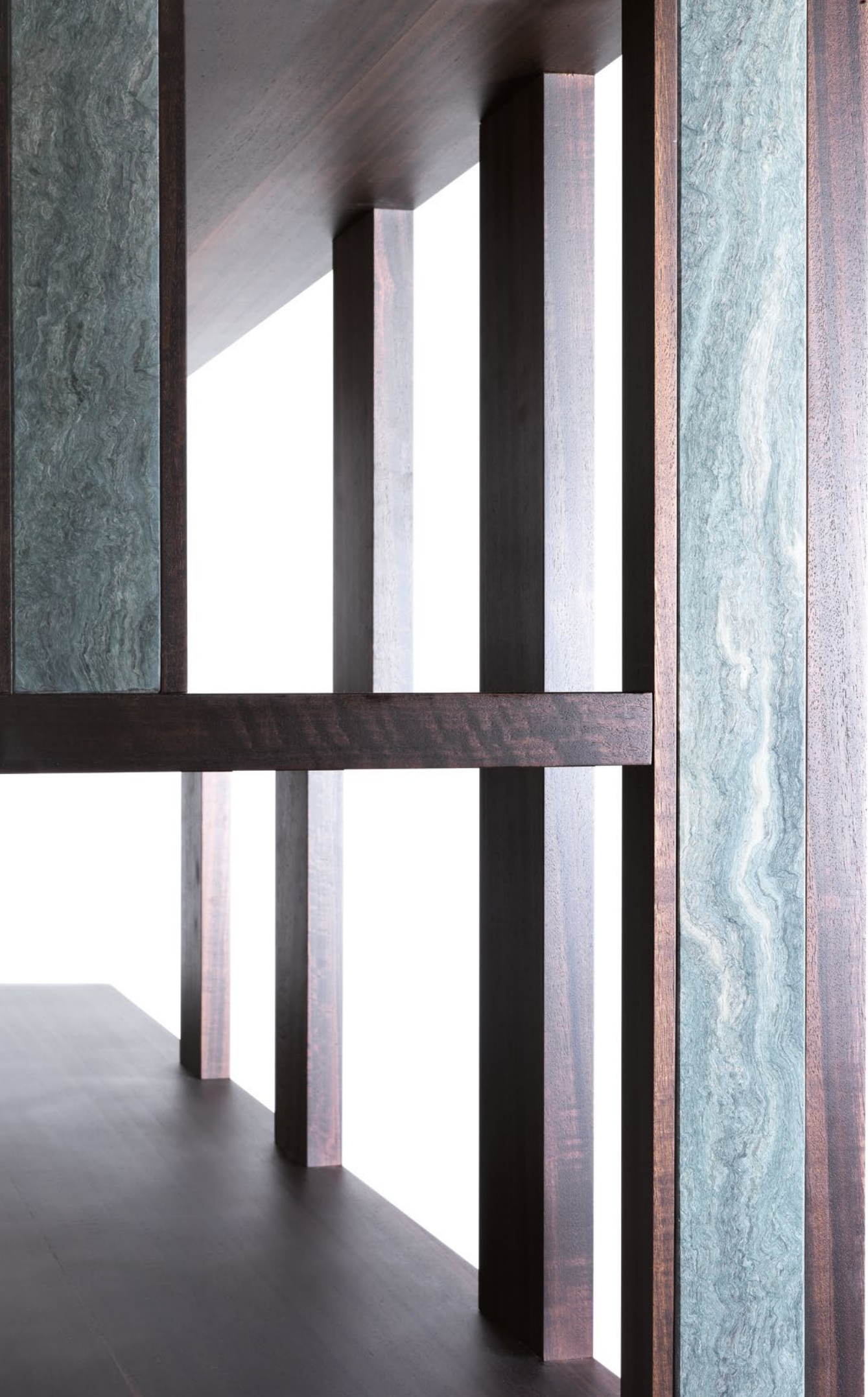

Vis à Vis

Design by
Enzo Berti



Chaise longue 119

Vis à Vis

Un parallelepipedo dall'immagine monolitica, disponibile in sei diverse tipologie di marmo, costituisce il perno strutturale e visivo di Vis-à-Vis, il sistema di chaise longue disegnato da Enzo Berti che nella versione doppia trova la sua espressione più significativa. Dal blocco centrale in pietra naturale fuoriescono quindi due elementi tubolari cromati, posti alla stessa quota, che sostengono una seduta relax, accessoriata con un comodo poggiatesta in lino e personalizzabile in corda, anche colorata, o altri intrecci naturali. L'insieme è materico ed essenziale allo stesso tempo e Vis-à-Vis, disponibile anche nel modello singolo, è concepita per arredare aree spa o ambienti outdoor.

A monolithic parallelepiped, available in six different types of marble, is the focal point of Vis-à-Vis, the chaise longue system designed by Enzo Berti that finds its most significant expression in the double version. From the main block in natural stone, two chromed tubular elements emerge, positioned at the same height, which hold a relaxing seat, accessorized with a comfortable headrest in linen and customizable in rope, also coloured, or other natural materials. The ensemble is materic and essential at the same time and Vis-à-Vis, also available in the single model, is conceived to furnish spa areas or outdoor environments.



Cat. Chaise longue
Design by **Enzo Berti** /
Year 12

★ Data sheet 144





- Chaise longue - **Vis à Vis**
Coffee table - **Torre**
Stool - **Pedina**
Washbasin - **Bowl 01**
Covering - **Zen**



Data Sheet



Tavoli e sedute / Tables and seating systems

Arcaico	130
Ellenico	131
Pluvio	131
Kalende Collection	132
More	133
Jackie	134
John	134
Nodo	135
Tangram Mini	136
Pedina	137
Torre - Torre Maxi	137
Moon	138

Keir	138-139
Keir Collection	138
Keir Table	139

Pavé Collection	140
Pavé Stones	140
Pavé Log and Drink	140

Oasi	141
-------------	-----

Librerie / Bookcases

Shiro	142
Tetris	143

Chaise longue

Vis à Vis	144
------------------	-----

Tavolo / Table

Arcaico

* Design by Enzo Berti pag. 8

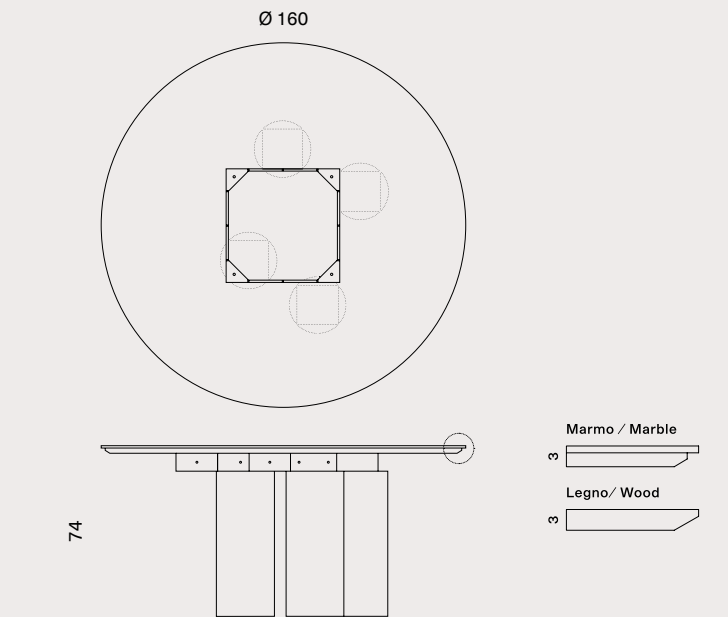
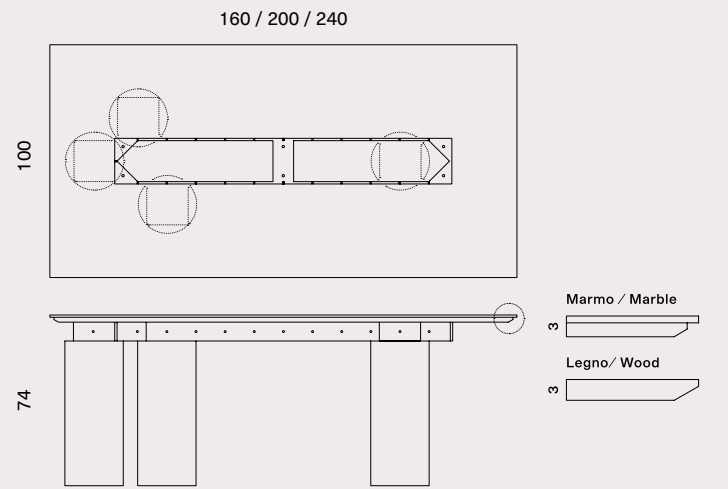

Top



Cilindri basi / cylinder bases



data sheet * table

Ellenico

* Design by Enzo Berti pag. 20

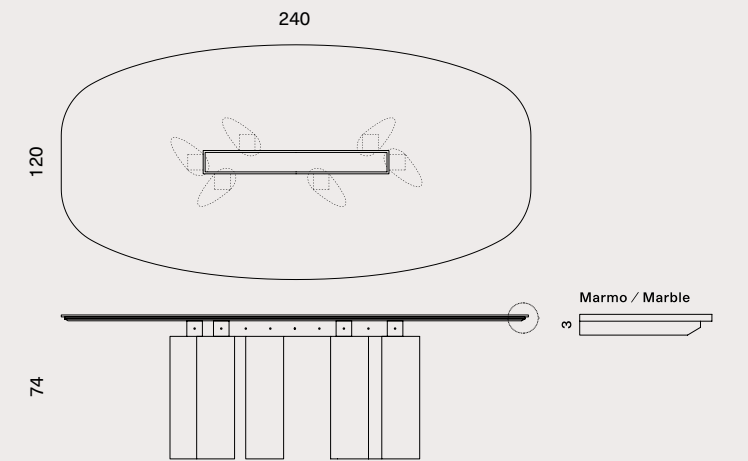

Pluvio

* Design by Matteo Nunziati pag. 26

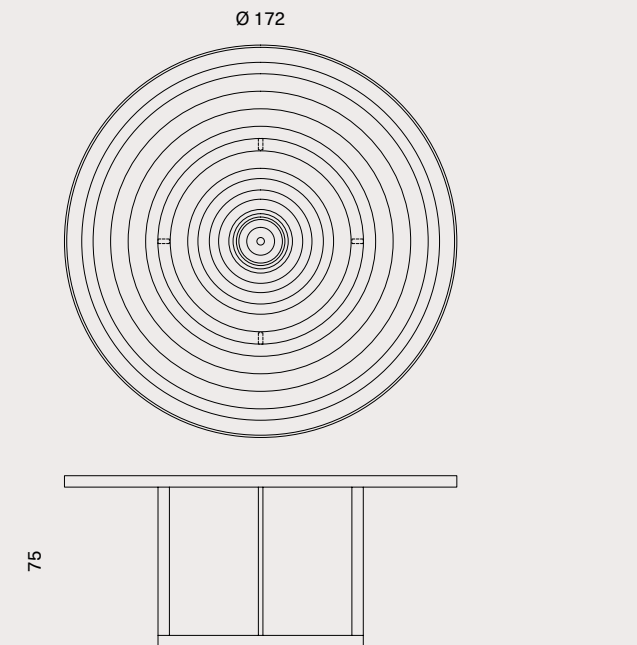

Top e basi / Top and bases



Marmo / Marble



Metalli / Metals

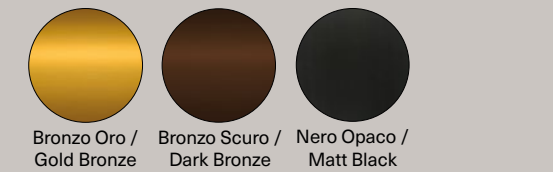

Kalende Collection

* Design by Enzo Berti
pag. 36

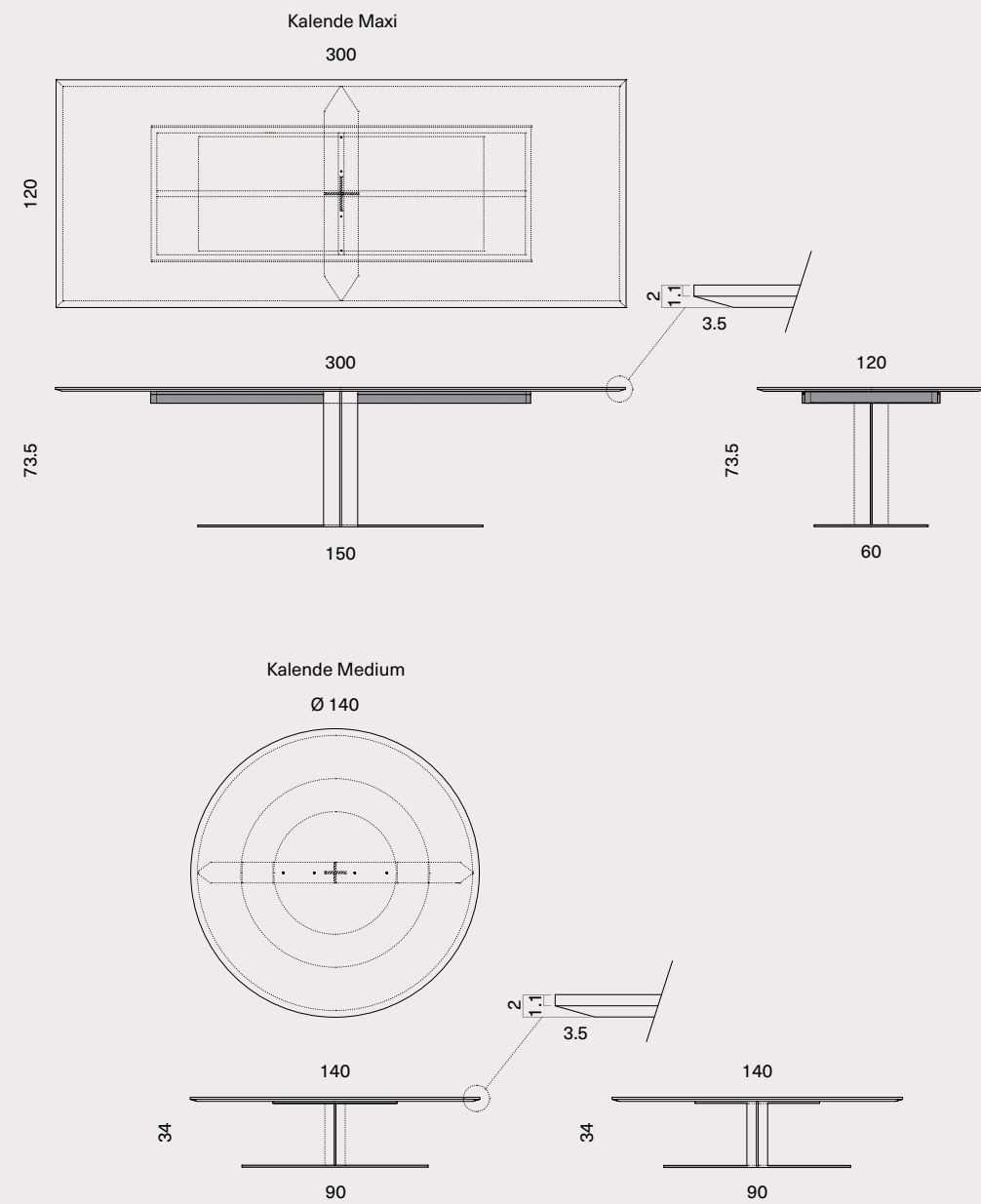

Marmo / Marble

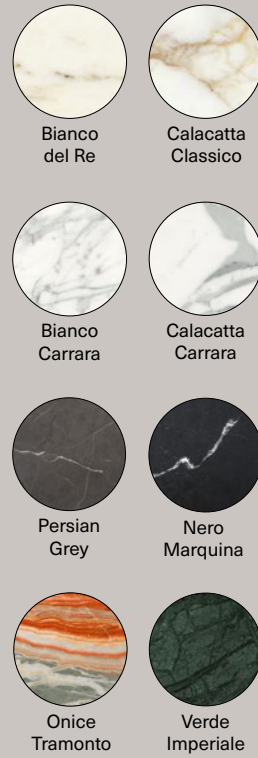

*Struttura del supporto
realizzata in metallo /
Support structure
made of metal

More

* Design by Marco Spatti
pag. 42

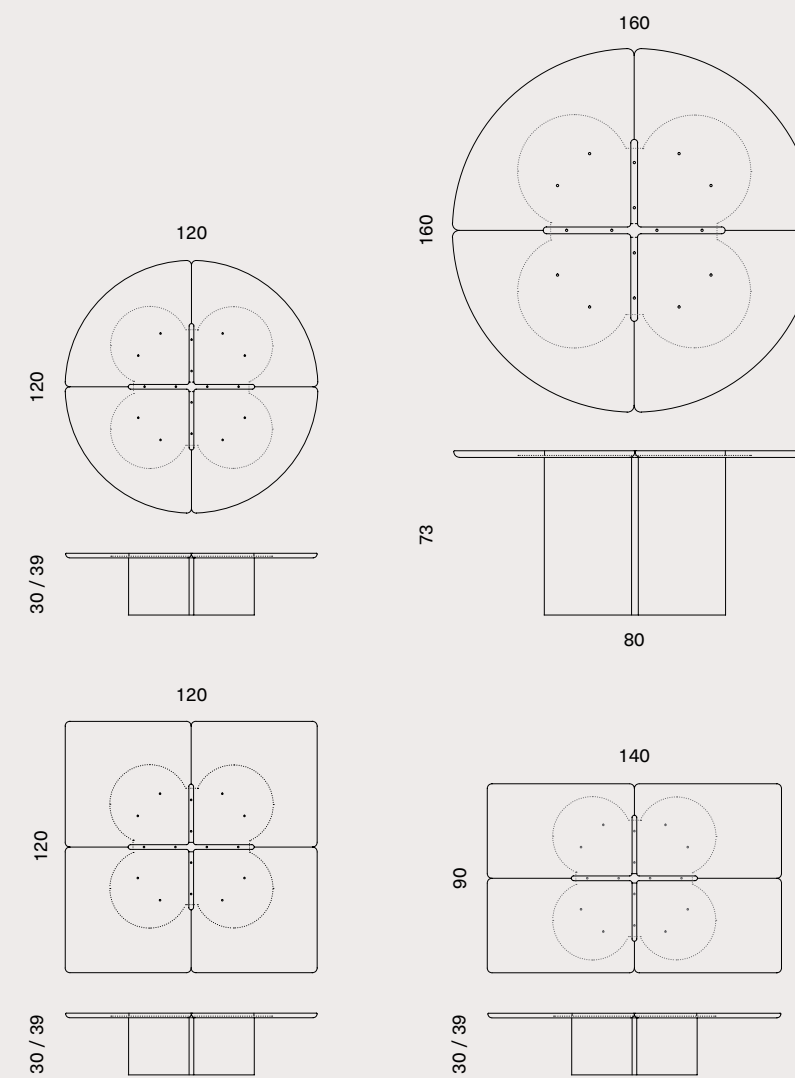

Top e basi / Top and bases



Tavolino / Coffee table

Jackie

* Design by Sebastiano Zilio
pag. 50

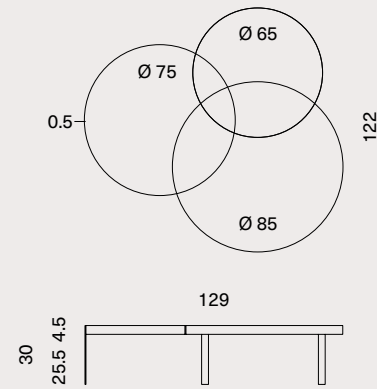

John

* Design by Sebastiano Zilio
pag. 54

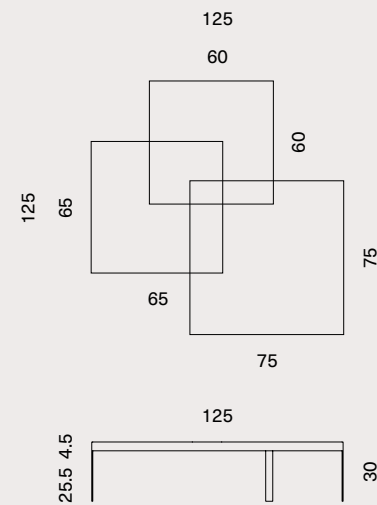

Marmo / Marble



Modern marble

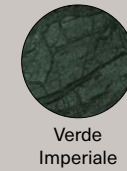
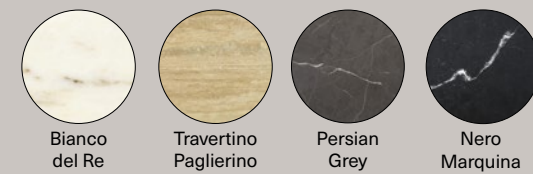

Luxury marble



data sheet * coffee table

Nodo

* Design by Enzo Berti
pag. 58

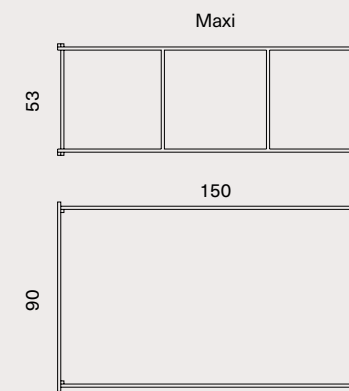
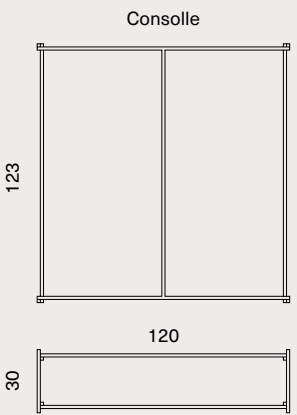
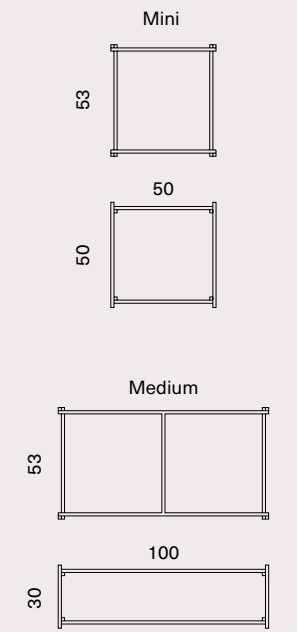

Struttura / Structure



* top disponibile anche con finitura ducale di Coverings Collection / top also available with Ducale finish from Coverings Collection

Tangram Mini

* Design by Enzo Berti
pag. 64

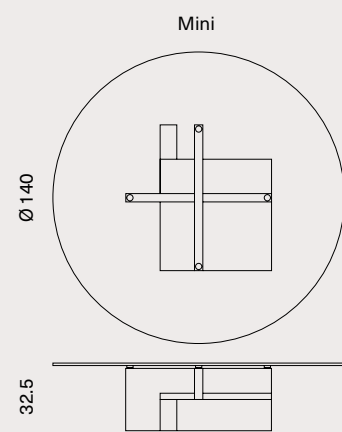
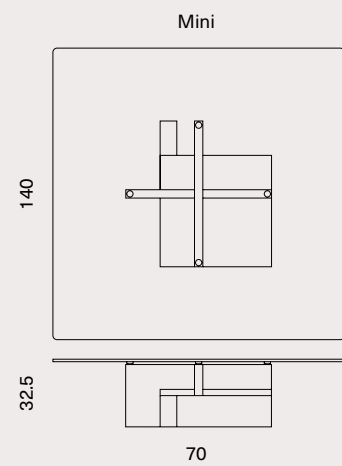

Struttura / Structure



Top



Tavolo, tavolino e sistema di sedute / Table, coffee table and seating system

Pedina

* Design by Enzo Berti
pag. 76

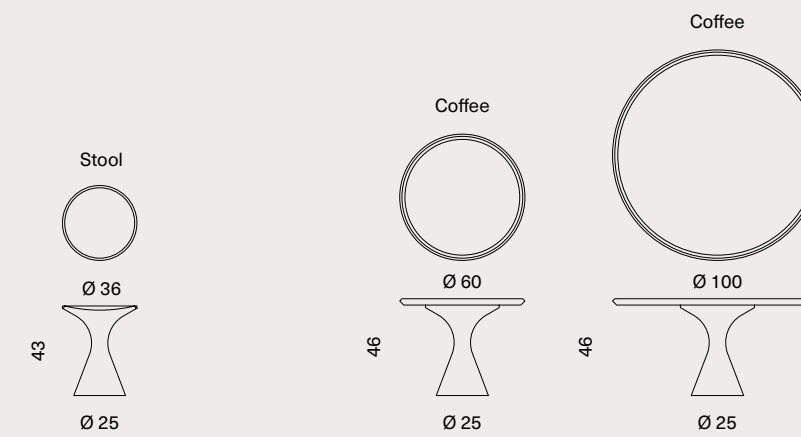

Sistema di sedute / Seating system

Tavolino / Coffee table

Marmo / Marble



Torre e Torre Maxi

* Design by Enzo Berti
pag. 30, 76

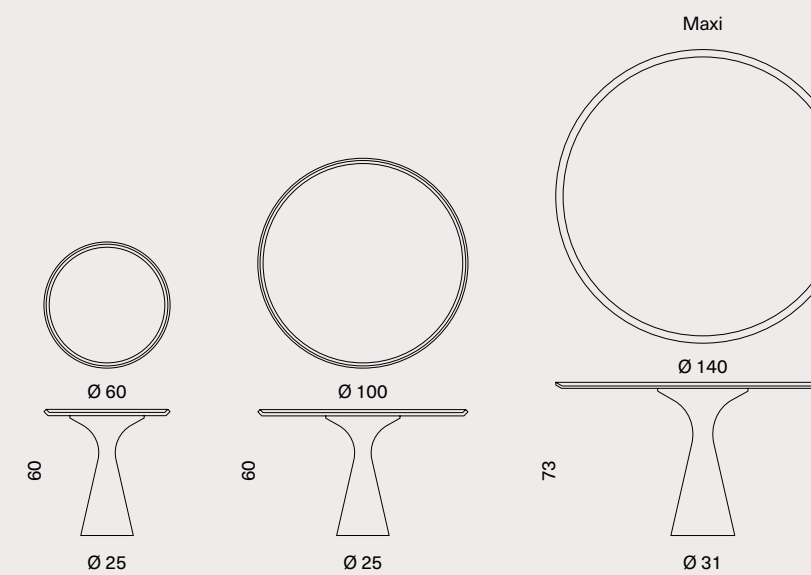

Marmo / Marble



Moon

* Design by Enzo Berti
pag. 70

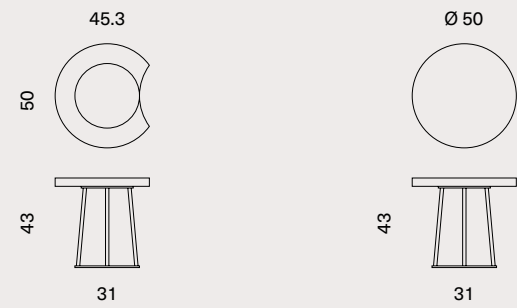

Sistema di sedute /
Seating system

Tavolino / Coffee table

Keir

Keir Collection

* Design by Enzo Berti
pag. 83-87

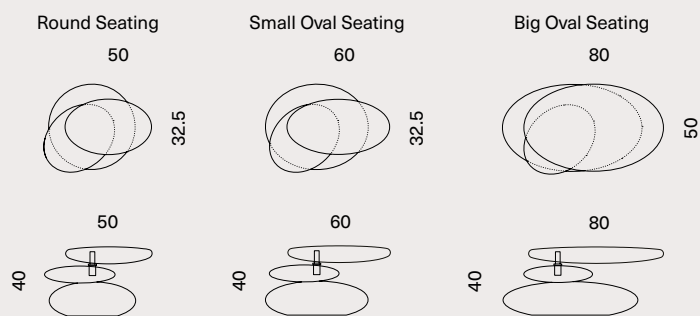
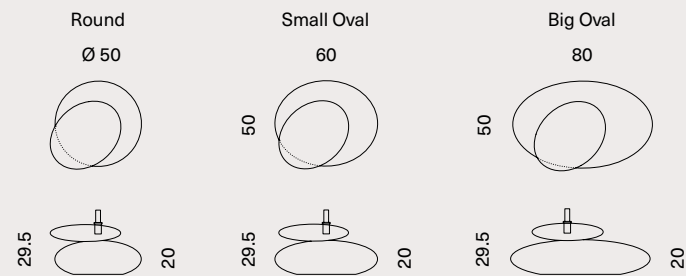

Marmo / Marble



Legno / Wood



Base in marmo / Marble base

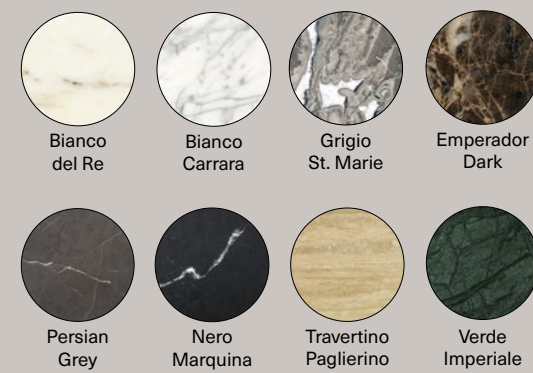

Seduta / Seat

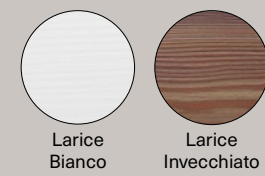

Keir Table

* Design by Enzo Berti
pag. 88-91

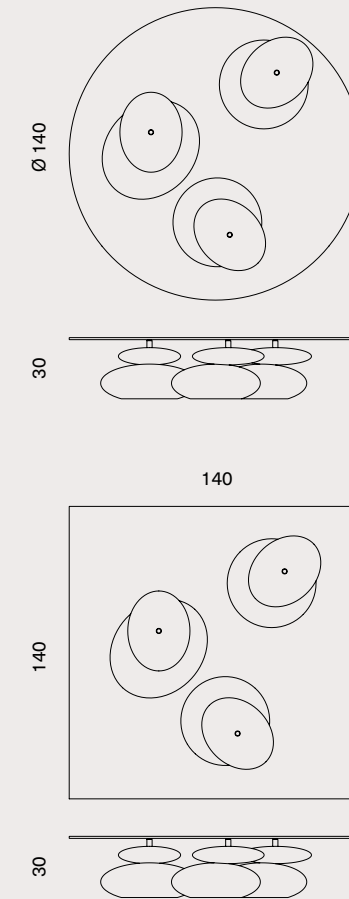

Marmo / Marble

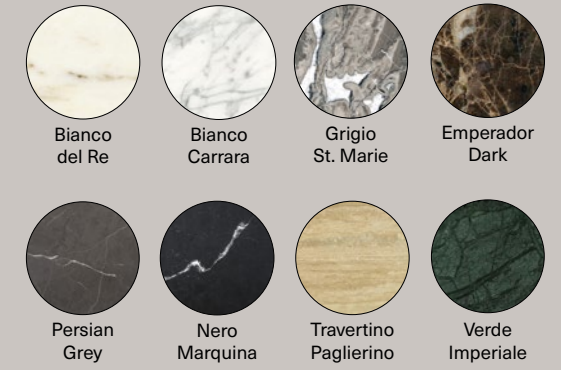

Top



Pavé Stones

* Design by Enzo Berti
pag. 95, 98-101

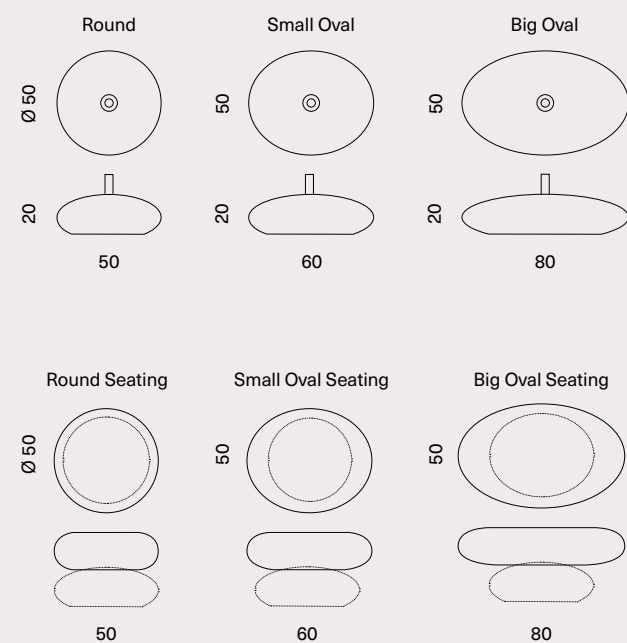

Pavé Log and Drink

* Design by Enzo Berti
pag. 96-99

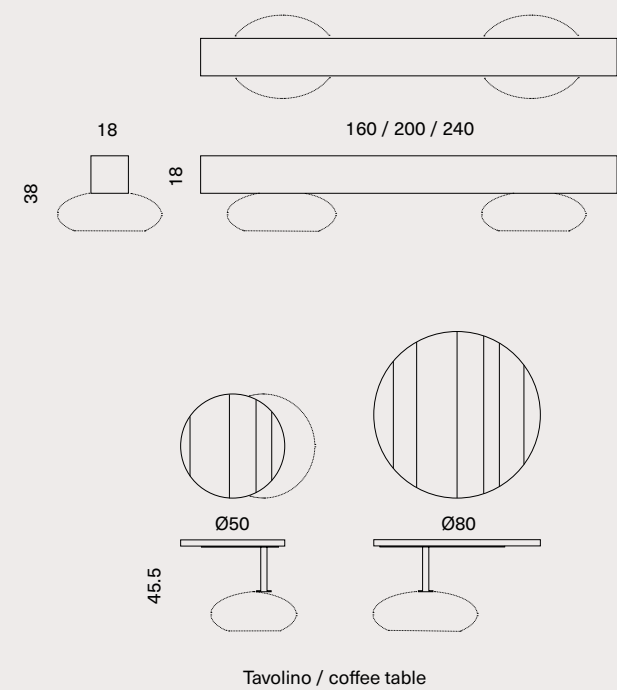

Base in marmo / Marble base



Seduta / Seat

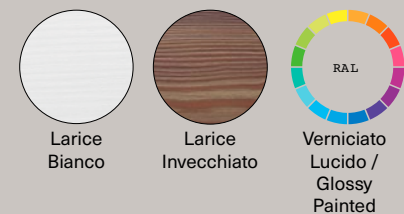

Legno / Wood



Copertura / Coverage



Pavé Drink Top

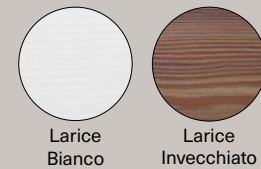

Oasi

* Design by Enzo Berti
pag. 104

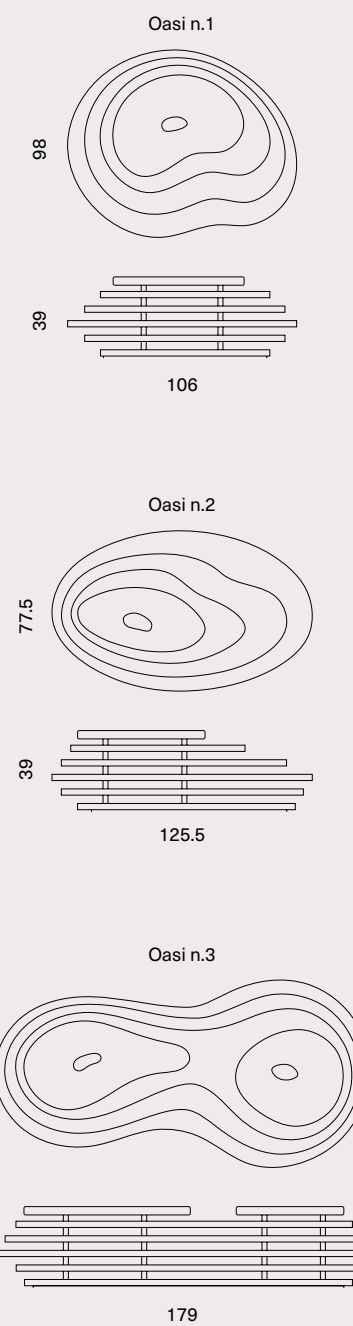

Base in marmo / Marble base



Legno / Wood

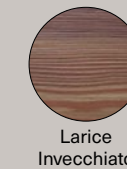

Shiro

* Design by Enzo Berti
pag. 110

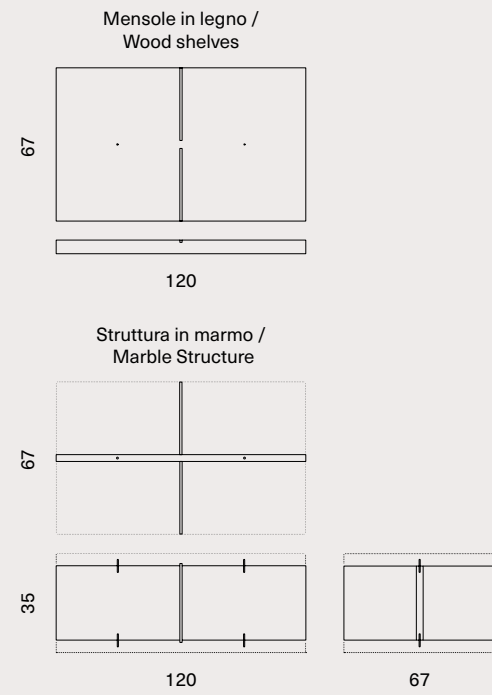
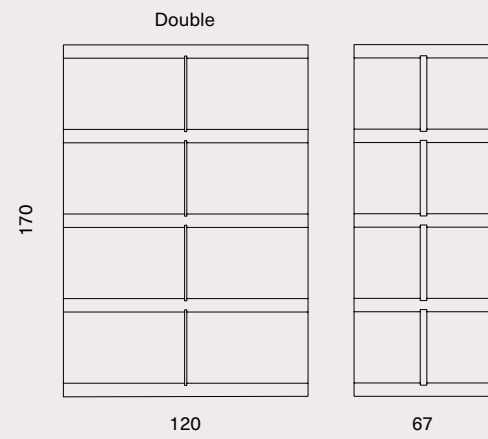
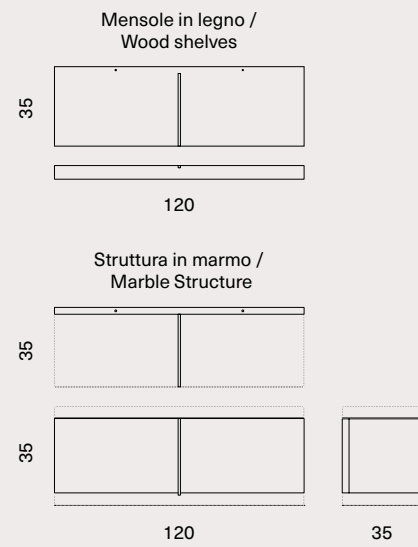
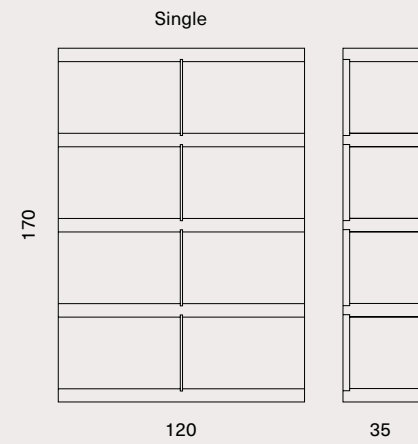

Marmo / Marble

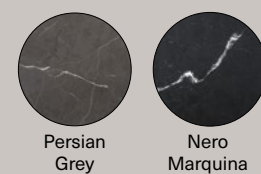
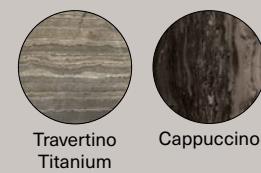
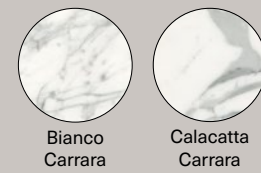

Mensole / Shelves



Tetris

* Design by Matteo Nunziati
pag. 114

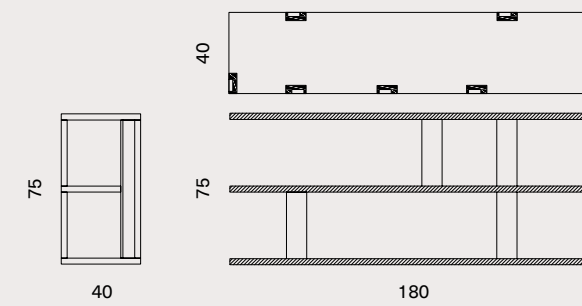
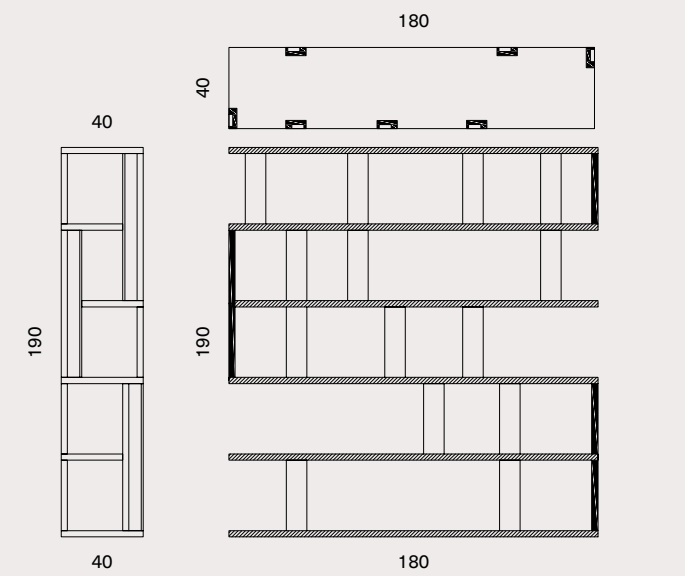

Legno / Wood



Dettagli in marmo / Marble details

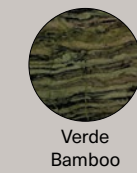
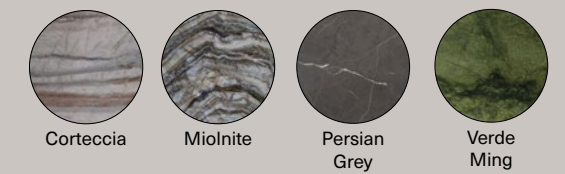
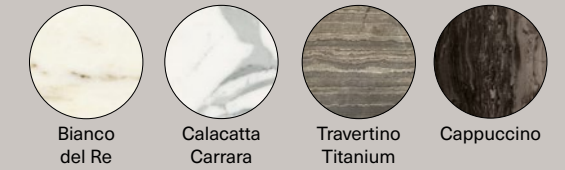

Chaise longue

Vis à Vis

* Design by Enzo Berti
pag. 120

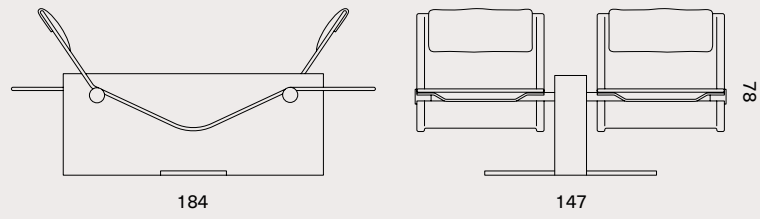
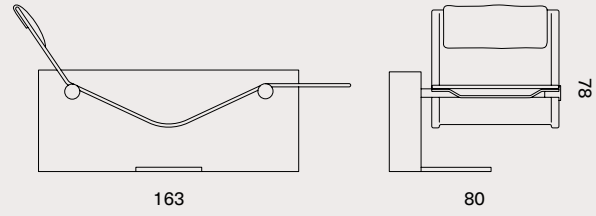

Marmo / Marble



Bianco del Re

Calacatta Classico

Bianco Carrara

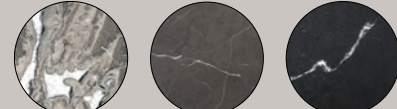

Grigio St. Marie

Persian Grey

Nero Marquina

Seduta / Seat

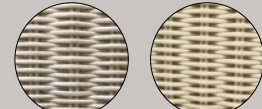

Midollino Naturale / Natural Wicker

Midollino Tecnico / Technical Wicker

Per sua natura ogni marmo o pietra presenta colori, venature e fessure uniche, che attestano ed esaltano le qualità di naturalezza e unicità del prodotto. Kreoo si riserva la facoltà di apportare ai propri modelli qualsiasi modifica tecnica, nelle dimensioni e nei colori, ritenuta necessaria, nonché la facoltà di sospendere la produzione in qualunque momento senza preavviso, rinunziata fin d'ora da parte del committente ogni conseguente richiesta risarcitoria. Si declina ogni responsabilità relativa ad eventuali inesattezze contenute in questo catalogo, se dovute ad errori di stampa o trascrizioni.

Each marble or limestone can present different colors and veins that exalt and confirm its naturalness and uniqueness. Note: Kreoo reserves the right to make any and all necessary technical, colour or size modifications to the furniture in order to enhance its use and esthetic value, and may suspend the production cycle at any moment without notice. Such instances may not be subject to claim by the client. We decline all responsibilities for any possible uncertainties due to misprints in this catalogue.

Kreoo
Via Duca d'Aosta, n°17 / e
36072, Chiampo
Vicenza - Italy
P.iva 02799900242

Ph (39) 0444 68 8311
info@kreoo.com
www.kreoo.com

Art direction
— Enzo Berti

Concept and
graphic design
— Giovanni Longhin
— Nicol Cassandro

Photography
— Tobia Berti

3d images
— Truetopia

Stylist
— Cristina Romanello

Printed by
— Grafiche Antiga

kreoo

Via Duca d'Aosta, n°17 / e
36072, Chiampo
Vicenza - Italy
P.iva 02799900242

Ph (39) 0444 68 8311
info@kreoo.com
www.kreoo.com

