

COLLECTION 2024

kreoo

COLLECTION 2024

kreoo

LIVING

- 6, **STERLING**
- 10, **SHADOW**
- 14, **HOLLY**
- 18, **EVER**
- 22, **QUEEN**
- 26, **MAJESTY**
- 30, **FANTASY**
- 34, **STARS**

FURNITURE ACCESSORIES /
COMPLEMENTI

- 38, **WISH (DIAGONAL)**
- 40, **WISH (GEOMETRIC)**
- 44, **TREASURE S - M - L - XL**
- 48, **ROYAL S - M - L**
- 52, **TRINITY S - M - L**
- 54, **PRINCESS S - M - L**
- 58, **IMPERIAL S - M - L**

BATHROOM / BAGNO

- 62, **MERCY**
- 68, **BLESSED TUB (CIRCLE)**
- 72, **PEARL**
- 74, **SILVER (CIRCLE)**
- 78, **SOUTHWELL**
- 82, **SHADE (SQUARE)**
- 86, **EMPIRE**
- 90, **BLESSED
(CIRCLE - SQUARE)**
- 94, **DAME FREESTANDING**
- 98, **TAO**



KREOO





In an era when time is measured in millennia and value lies in eternity, an Italian company embraces the beauty of marble with passion and ancestral mastery - letting it evolve towards outstanding aesthetic rhetoric.

Kreoo brings to new light the primordial charm of a material that has witnessed the evolution of civilizations and cultures. Its presence in Roman ruins, majestic Renaissance palaces, and masterpieces of Italian architecture, testifies to a historical process that has engraved its stylistic codes and messages in stone blocks. According to the Century, tradition has shaped stone, preserving secret knowledge and extraordinary dedication, but still surviving through the skilled hands of Kreoo's craftsmen who are entrusted with preserving the millenary art of shaping stone to create today's designs. Each piece becomes an ode to earth and men's creative genius, but also a bridge between past and present, and an anthology of design and art.

Kreoo defines a bond with the most authentic roots of our heritage, preserves its know-how, and braids it with a contemporary language. The result is an exciting narrative of a noble, timeless, and unique material.

In un'epoca in cui il tempo si misura in millenni e il valore risiede nell'eternità, c'è un'azienda italiana che abbraccia la bellezza del marmo con passione e maestria ancestrale, per farla evolvere verso un'inedita retorica estetica.

Kreoo porta a una nuova luce il fascino primordiale di una materia che ha testimoniato l'evolversi di civiltà e culture. La sua presenza nelle rovine romane, nei maestosi palazzi rinascimentali, nei capolavori dell'architettura italiana, è testimonianza di un processo storico che ha inciso nei blocchi lapidei i propri codici stilistici e i messaggi più elevati. Di secolo in secolo, la tradizione ha modificato le forme, nutrendosi sempre di un sapere segreto e di una dedizione straordinaria, che continua a vivere attraverso le sapienti mani degli artigiani di Kreoo. A loro è affidato il compito di preservare l'arte millenaria di plasmare la pietra, per realizzare le creazioni di oggi: ogni pezzo diventa un'ode alla terra e al genio creativo dell'uomo, un ponte tra passato e presente, un'antologia di design e arte.

Kreoo stabilisce un legame vivo con le radici più autentiche del nostro patrimonio, ne custodisce il know-how e lo intreccia con un linguaggio contemporaneo, per restituire una narrazione emozionante di una materia nobile, viva, immortale, unica.



STERLING

LIVING

SEATINGS / SEDUTE

Sterling is a monolithic armchair. The main shell is made by two round portions carved out from natural stone block; they extend to create base and seatback, becoming both decorative and functional.

Sterling è una poltroncina dall'immagine monolitica. Due setti curvi, modellati e plasmati nella pietra naturale, definiscono la scocca: si estendono per creare base e schienale, diventando sia decorativi che funzionali.





SHADOW

LIVING

SEATINGS / SEDUTE

The contrast between sharp, linear profiles and soft, radiating forms evokes a harmonious, balanced and unique aesthetic in the Shadow bench. Designed for indoor and outdoor and in various kinds of projects.

Il contrasto tra profili netti e lineari e forme morbide e raggiate suscita un'estetica armoniosa, equilibrata e unica nella panca Shadow. Pensato per essere inserito in ambienti indoor e outdoor e in differenti tipologie di progetto.





HOLLY

LIVING

SEATINGS / SEDUTE

By the crafting of marble with sinuous and soft profiles the Holly seating collection is born. It features a bucket-style armchair, whose shell is carved and shaped to become an ergonomic and enveloping cocoon, with a play of curves and different depths. The stone seat surface is complemented by a soft cushion covered in leather or fabric with visible stitching.

Dalla lavorazione del marmo con profili sinuosi e morbidi nasce la collezione di sedute Holly. È una poltroncina a pozzetto, la cui scocca è scavata e plasmata per diventare un guscio ergonomico e avvolgente, con un gioco di curvature e differenti profondità. Il piano lapideo dedicato alla seduta è completato con un morbido cuscino rivestito in pelle o tessuto e con impunture a vista.





EVER

LIVING

SEATINGS / SEDUTE

The Ever bench proposes a geometric interlocking of marble slabs of different thicknesses. Suitable for indoor and outdoor environments, it features a 4 cm thick seat surface, with two small edges on the lower sides that allow for the placement of cushions.

La panca Ever propone un incastro geometrico di lastre in marmo di differenti spessori. Dedicata ad ambienti indoor e outdoor, prevede una superficie di seduta dello spessore di 4 cm, con due piccole bordature sui lati inferiori che permettono di contenere cuscini.





QUEEN

LIVING

TABLE / TAVOLO

The elegance and simplicity of design meet material richness in the Queen table. The base, is formed by three trapezoidal-shaped sections with chamfered corners; even their edges are radiused and soft to enhance the veins of the natural stone, while the matt finish creates an almost velvety effect on the surface.

L'eleganza e la semplicità del disegno incontra la ricchezza materica nel tavolo Queen. La base, è formata da tre setti dalla forma trapezoidale, con angoli smussati; anche la loro costa è raggiata e morbida, per esaltare le venature della pietra naturale, mentre la finitura opaca crea un effetto quasi vellutato sulla superficie.





MAJESTY

LIVING

TABLE / TAVOLO

Majestic, impressive, sculptural. Majesty table is a composition of geometries that forms a piece of furniture measuring 300x100 cm. The geometries are sharp, precise and clean, while the material effect is extremely vivid and deep thanks to the veins and nuances of the natural stone emerging from the constructive interplay of the structure.

Massiccio, importante, scultoreo, il tavolo Majesty è una composizione di geometrie che formano un arredo della dimensione di 300x100 cm. Le geometrie sono nette, precise, pulite, mentre l'effetto materico è estremamente vivido e profondo, grazie alle venature e nuance della pietra naturale che emergono dal gioco costruttivo della struttura.





FANTASY

LIVING

SEATINGS / SEDUTE

Fantasy is a versatile and functional piece of furniture initially conceived as a compact stool, its marble craftsmanship yields intricate and sophisticated details. However, it can also serve as a footrest in front of a sofa or armchair, creating an elegant material and formal contrast.

Versatile e funzionale, Fantasy nasce come sgabello dalle dimensioni compatte, in cui la lavorazione del marmo crea dettagli complessi e sofisticati, ma può essere impiegato anche come poggiatesta, davanti a un divano o una poltrona, in un elegante contrasto materico e formale.





STARS

LIVING

SEATINGS / SEDUTE

A light curvature of the seating surface, identical in its upper and lower parts, breaks the simplicity of the design of the stackable Stars stools. Entirely made of marble, they originate from an element which unfolds according to an inverted U-shaped profile to create the two base sections and the seat, seamlessly connected with a soft and radiused finish.

Una leggera curvatura della superficie di seduta, identica nella sua parte superiore e inferiore, rompe la semplicità del disegno degli sgabelli impilabili Stars. Interamente in marmo, nascono da un elemento che si snoda secondo un profilo a U rovesciato per realizzare i due setti di base e la seduta, che si raccorda con una lavorazione morbida e raggiata.





WISH (DIAGONAL)

FURNITURE ACCESSORIES / COMPLEMENTI

Wish is an exemplary collection of Kreoo's know-how in marble processing and its integration of industrial techniques and artisan care.

Il know-how di Kreoo nella lavorazione del marmo e la sua capacità di associare tecniche industriali a cura artigianale e lavorazione manuale è enfatizzato dalla collezione Wish.



WISH (GEOMETRIC)

FURNITURE ACCESSORIES / COMPLEMENTI

Wish is an exemplary collection of Kreoo's know-how in marble processing and its integration of industrial techniques and artisan care.

Il know-how di Kreoo nella lavorazione del marmo e la sua capacità di associare tecniche industriali a cura artigianale e lavorazione manuale è enfatizzato dalla collezione Wish.





TREASURE S - M - L - XL

FURNITURE ACCESSORIES / COMPLEMENTI

Treasure is a composition of shapes and colours. The collection is made by four slender candlesticks that alternate elegant sculpted portions and moulded in marble according to different designs, creating a polychromatic and precious furnishing item. Imagined as freestanding complement, approximately 150 cm high.

Treasure è una composizione di forme e colori. La collezione comprende quattro candelabri slanciati, che alternano eleganti porzioni plasmate e modellate in marmo secondo differenti disegni e creano un oggetto di arredo policromo e prezioso. Sono immaginati come complementi freestanding, con un'altezza di circa 150 cm.





ROYAL S - M - L

FURNITURE ACCESSORIES / COMPLEMENTI

A line of marble furniture accessories consisting of three vases with slim and elegant shapes. The main body has a sinuous shape and an inverted border on the upper profile, enabling a dovetail cover.

Una linea di complementi di arredo in marmo, con tre vasi dalla forma slanciata ed elegante. Il corpo presenta una forma morbida e una bordatura arretrata sul profilo superiore che permette l'incastro della copertura.





TRINITY S - M - L

FURNITURE ACCESSORIES / COMPLEMENTI

The Trinity collection is a family of candleholders in three different where the design of the base is inscribed within a square, and the connection between the various elements is achieved through a subtle radiused marble processing.

La collezione Trinity è una famiglia di candelieri in tre differenti altezze dove il disegno della base è iscritto in un quadrato e il raccordo tra i vari elementi è realizzato attraverso una leggera lavorazione raggiata del marmo.



PRINCESS S - M - L

FURNITURE ACCESSORIES / COMPLEMENTI

Princess is a line of marble vases ideal to embellish indoor and outdoor spaces. The elegant craftsmanship combined with minimal thickness emphasizes the veins of the natural stone.

Princess è una linea di vasi in marmo ideali per decorare ambienti indoor e outdoor. L'elegante lavorazione, unita allo spessore portato al minimo, enfatizza le venature della pietra naturale.





IMPERIAL S - M - L

FURNITURE ACCESSORIES / COMPLEMENTI

Soft profiles emerging from an encounter of geometries characterize the Imperial collection.
It's a family of marble accessories dedicated to decorating interior design projects.

Morbidi profili che nascono da un incontro di geometrie emergono dalla collezione Imperial.
È una famiglia di complementi in marmo dedicati a decorare i progetti di interior design.







MERCY

BATHROOM / BAGNO

WASHBASINS / LAVABI

Mercy is a sculptural freestanding sink that celebrates the vocation of natural stone. The result is an evolving work of art, the product of complex processing between technology and craftsmanship, envisioned to become the centrepiece of a bathroom environment in high-end residential or hospitality projects.

Mercy è un lavabo freestanding scultura che esalta la vocazione della pietra naturale. Ne emerge un'opera d'arte in evoluzione, frutto di una complessa elaborazione tra tecnologia e sapere artigianale, immaginata per diventare protagonista di un ambiente bagno, in progetti high-end residenziali o di hospitality.





BLESSED TUB (CIRCLE)

BATHROOM / BAGNO

BATHTUBS / VASCHE

The evolution of the Blessed collection maintains its aesthetic foundation unchanged. In the freestanding bathtub version, with elongated oval or rectangle, the range dedicated to the world of bathroom is characterized by the material contrast between the outer and inner surfaces.

L'evoluzione della collezione Blessed ne mantiene invariata la matrice estetica. Nella versione vasca freestanding, con forma ovale allungata o rettangolare, la gamma dedicata al mondo bagno è caratterizzata dal contrasto materico tra superficie esterna e interna.





PEARL

BATHROOM / BAGNO

BATHTUBS / VASCHE

Pearl bathtub is inspired by the tiny opaline universe hidden within a rough asymmetric shell. The internal ergonomic shell exudes the metaphor of the "pearl", realized through the wellness-based detailing of the Airpool system.

La vasca Pearl si ispira al minuscolo universo opalino nascosto all'interno di un guscio grezzo e asimmetrico. La scocca interna ergonomica evoca la metafora della "perla", realizzata attraverso i dettagli orientati al benessere del sistema Airpool.

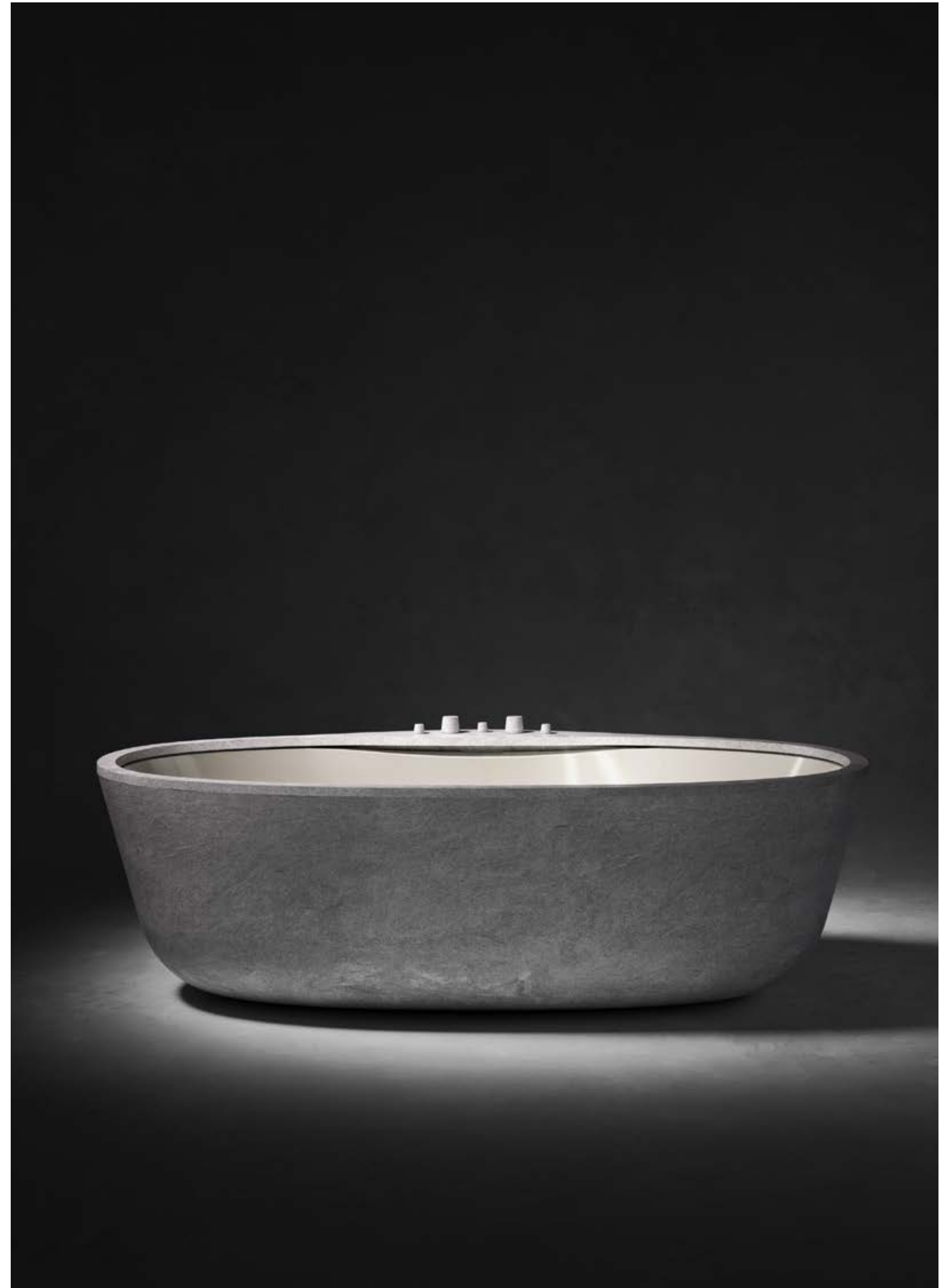

SILVER (CIRCLE)

BATHROOM / BAGNO

BATHTUBS / VASCHE

The purity of the square and the circle inspires Silver collection of freestanding bathtubs: essential forms that evoke ancestral wellness rituals, with their compact dimensions and their composition entirely in marble.

La purezza del quadrato e del cerchio ispirano la collezione di vasche freestanding Silver: forme essenziali che rievocano rituali di benessere ancestrali, con le loro dimensioni compatte e la loro composizione interamente in marmo.





SOUTHWELL

BATHROOM / BAGNO

SHOWER TRAY / PIATTI DOCCIA

Sculptural and with significant dimensions, Southwell reimagines the concept of the shower tray, bringing it to a macro scale effect with a diameter of 140 cm. It features a radiused border, with a soft finish on the outer surface and a relevant thickness.

Scultoreo e dalle dimensioni importanti, Southwell declina il tema di piatto doccia, portandolo ad un effetto in macro scala, con un diametro di 140 cm. È caratterizzato da una bordatura raggiata, con una morbida lavorazione sulla superficie esterna e uno spessore rilevante.





SHADE (SQUARE)

BATHROOM / BAGNO

WASHBASINS / LAVABI

Shade is a collection of marble shower trays designed to be positioned at the centre of a space, creating areas of wellness with strong evocative power. Available in two shapes - square and circle - the elements feature inclined edges, confirming their freestanding placement, while the drain is seamlessly integrated into the surface and also made of natural stone.

Shade è una collezione di piatti doccia in marmo da posizionare al centro di un ambiente, per costruire aree di benessere dal forte potere evocativo. In due forme - il quadrato e il cerchio -, gli elementi presentano bordi inclinati, che ne confermano la collocazione freestanding, mentre la piletta è intagliata a filo della superficie e realizzata sempre in pietra naturale.





EMPIRE

BATHROOM / BAGNO

WASHBASINS / LAVABI

With its light and minimalist aesthetics, Empire takes the shape of an extended 11 cm high rectangle, with thin edges and square corners. Inside, there are two distinct functional areas: one dedicated to the traditional theme of water and washing; the other offers a practical raised shelf where you can place personal hygiene accessories.

Dall'estetica leggera e minimale, il lavabo Empire ha forma di rettangolo allungato, con bordi sottili, dell'altezza di 11 cm, e angoli squadri. Al suo interno sono previste due aree funzionali distinte: una, dedicata al tradizionale tema dell'acqua e del lavaggio; l'altra offre un pratico ripiano rialzato su cui poggiare accessori per l'igiene personale.





BLESSED (CIRCLE - SQUARE)

BATHROOM / BAGNO

WASHBASINS / LAVABI

In the Blessed collection of countertop washbasins, the internal and external surface create an elegant and customizable contrast. The combination of materials, selectable between the different proposals with different veins and shades, then finds the meeting point in the upper edge, hand-worked on the entire profile to obtain an extremely thin thickness, extraordinary if associated with natural stone.

Nella collezione di lavabi da appoggio Blessed la superficie interna ed esterna creano un contrasto elegante e personalizzabile. Il binomio di materiali, selezionabili tra le differenti proposte con venature e tonalità diverse, trova quindi il punto di incontro nel bordo superiore, lavorato a mano su tutto il profilo per ottenere uno spessore estremamente sottile, straordinario se associato alla pietra naturale.





DAME FREESTANDING

BATHROOM / BAGNO

WASHBASINS / LAVABI

Dame Freestanding is the celebration of different aesthetics coming to life as works of art for the bathroom. A design that is born from the dichotomy between classic and contemporary, minimal and decorative.

Dame Freestanding è la celebrazione di estetiche diverse che prendono vita come opere d'arte dedicate all'ambiente bagno. Un design che nasce dalla dicotomia tra classico e contemporaneo, minimale e decorativo.





BATHROOM / BAGNO

WASHBASINS / LAVABI

The freestanding Tao washbasin, designed by Marco Piva, combines elegance and functionality with a cylindrical design in marble crossed by thin brass strips. This structure not only adds a touch of luxury but also optimizes material usage, ensuring a refined and versatile aesthetic.

Il lavabo freestanding Tao, progettato da Marco Piva, unisce eleganza e funzionalità con un design cilindrico in marmo attraversato da sottili fasce in ottone. Questa struttura non solo conferisce un tocco di lusso, ma ottimizza l'utilizzo del materiale garantendo un'estetica raffinata e versatile.





TECHNICAL INFORMATION

LIVING

EVER

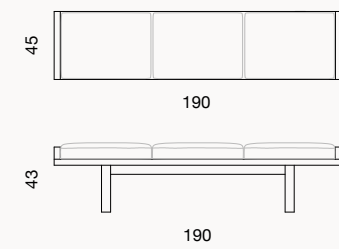

FANTASY

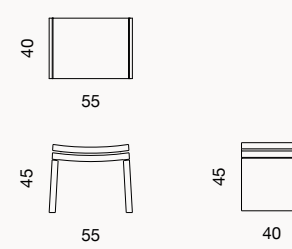

HOLLY

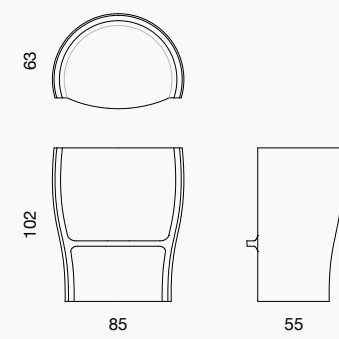

MAJESTY

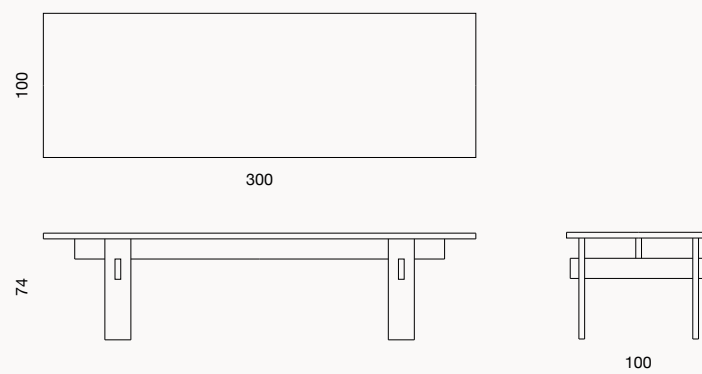

QUEEN

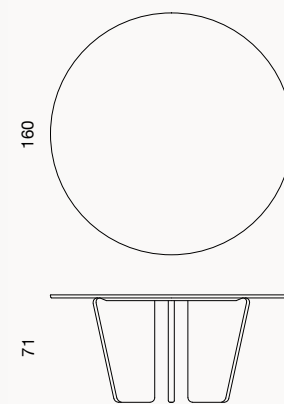

SHADOW

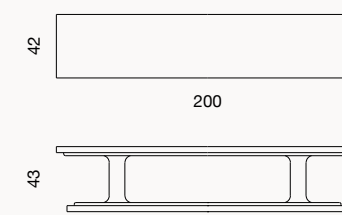

STARS

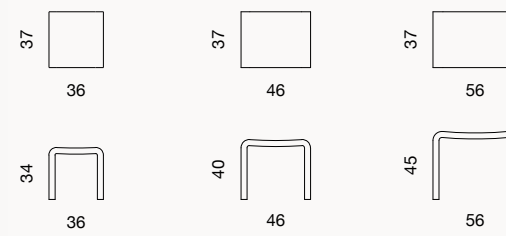

STERLING

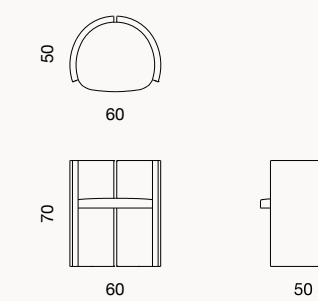

FURNITURE ACCESSORIES / COMPLEMENTI

IMPERIAL S - M - L

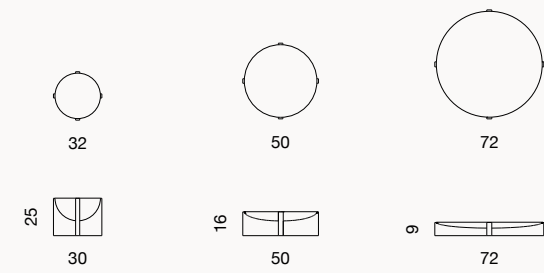

PRINCESS S - M - L

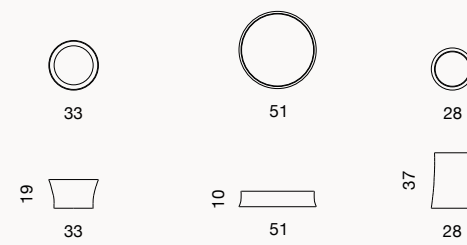

ROYAL S - M - L

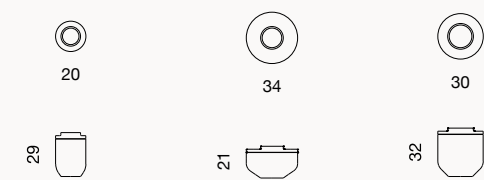

TREASURE S - M - L - XL

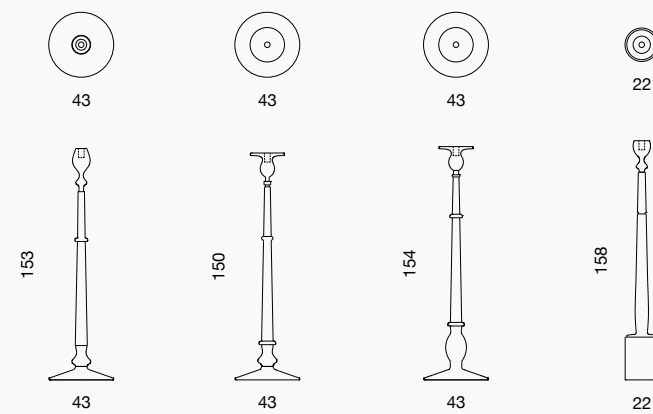

TRINITY

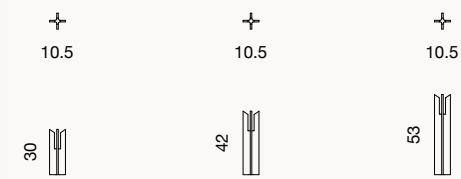

WISH (DIAGONAL - GEOMETRIC)

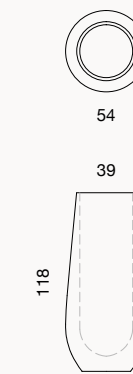

BATHROOM / BAGNO

BLESSED (CIRCLE - SQUARE)

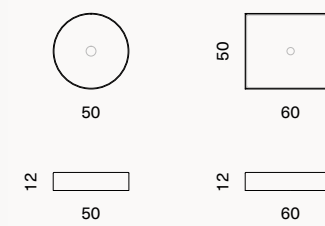

BLESSED TUB (CIRCLE)

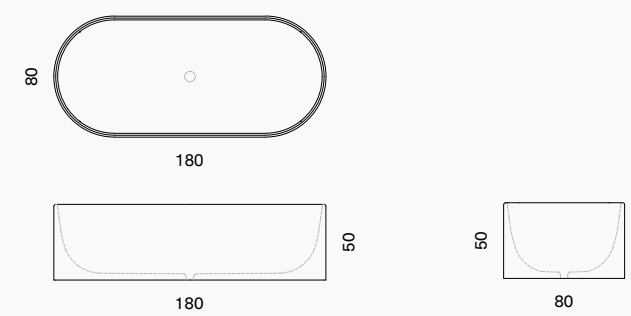

DAME FREESTANDING

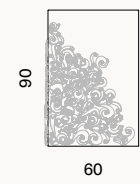
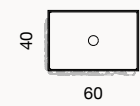

EMPIRE

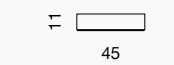
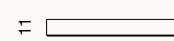
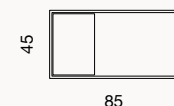

MERCY - MERCY SMALL



PEARL

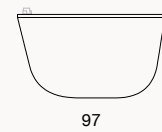
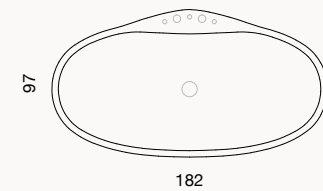

SOUTHWELL

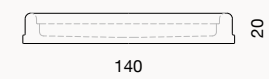
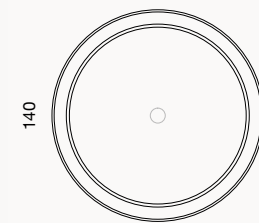

SHADE (SQUARE)

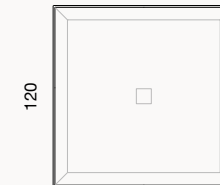

SILVER (CIRCLE)

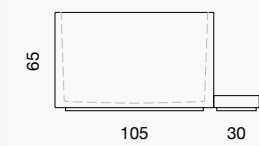
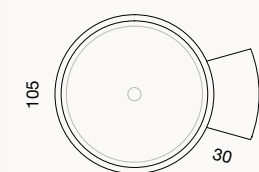

TAO

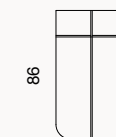

THANKS TO

ART DIRECTION

CHRISTOPHE PILLET

DESIGNER

ALBERTO APOSTOLI

CHRISTOPHE PILLET

MARCO PIVA

KREOO DESIGN STUDIO

CONCEPT

STUDIO SALARIS & VZNSTUDIO

GRAPHIC

VZNSTUDIO

PHOTO

LORENZO RUI

PRESS OFFICE

DESIGN FEVER

TAPS AND FITTINGS

ZANETTI CHINI

kreoo

DECORMARMI SRL

VIA DUCA D'AOSTA, N°17 / E

36072, CHIAMPO

VICENZA - ITALY

P.IVA 02799900242

PH (39) 0444 68 8311

INFO@KREOO.COM

KREOO.COM - DECORMARMI.COM

